



# TouchNet™

Central Control System  
for Network LTC™ *Plus*

## User's Guide

- ◆ Installation
- ◆ Programming
- ◆ Operation
- ◆ Service

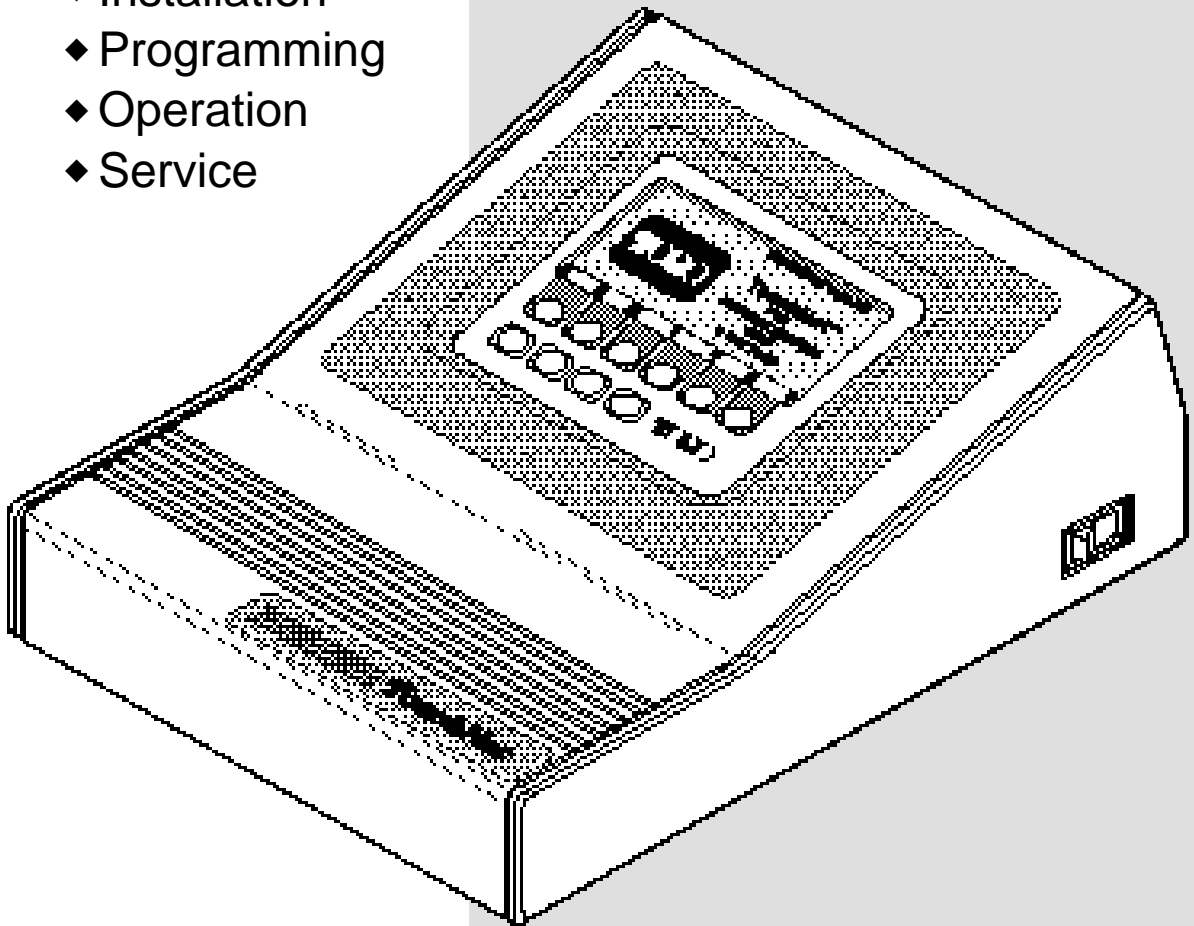



# Table of Contents

- Section 1:** Introduction To TouchNet .....1-2
- Section 2:** Installation Procedure .....3-10
- Section 3:** Getting Started .....11–21
  - About the System Type and Home Screens ...11
  - The Function Keys .....13
    - MENU .....13
    - TORO .....13
    - RAIN .....13
    - CANCEL .....14
    - MANUAL .....14
    - ADJUST .....14
    - STARTS .....14
  - Using Pop-Up Keypads .....14
  - Other Buttons on the TouchNet Central .....16
  - Configuring the Controller .....16
  - The Menu Screen .....16
  - System Setup .....16
  - Set Current Time .....17
  - Select Time Mode .....17
  - Set Current Date .....18
  - Select Date Display .....18
  - Set Day Change Time .....19
  - Automatic Download .....19
  - Set Flow Units .....20
  - Satellite Mode .....21
  - Satellite Lock .....21
- Section 4: Programming The Controller (Golf) .....23–41**
  - Golf Course Layout Example .....24
  - System and Satellite Worksheet Examples ...25
  - System Hydraulics Setup .....27
  - Watering Program Setup .....28
  - Naming Programs .....28
  - Setting Program Run Time and Flow .....30
  - Satellite Setup .....32
  - Satellite Station Setup .....34
  - A-Time (Adjusted Run Time) .....36
  - Master Watering Sequences .....36
  - The Starts Screen .....37
  - Set Watering Days .....38
  - Set Program Priority .....39
  - Sort Function Key .....40
  - Clear Function Key .....40
  - Set Syringe/Test Cycle Time .....40
  - Total Run Time Calculation .....41

# Table of Contents

- Section 4: Programming The Controller (Commercial) 42–59**
  - Commercial Site Layout Example . . . . .42
  - System and Satellite Worksheet Examples . . . .43
  - System Hydraulics Setup . . . . .45
  - Watering Program Setup . . . . .46
  - Naming Programs . . . . .46
  - Setting Program Run Time and Flow . . . . .48
  - Satellite Setup . . . . .50
  - Satellite Stations Setup . . . . .52
  - A-Time (Adjusted Run Time) . . . . .54
  - Master Watering Sequences . . . . .54
  - The Starts Screen . . . . .55
  - Set Watering Days . . . . .56
  - Set Program Priority . . . . .57
  - Sort Function Key . . . . .58
  - Clear Function Key . . . . .58
  - Set Syringe/Test Cycle Time . . . . .58
  - Total Run Time Calculation . . . . .59
- Section 5: Switch Programs . . . . .60–63**
- Section 6: Manual Operations . . . . .64–66**
- Section 7: Special TouchNet Features . . . . .67–85**
  - Rain Delay . . . . .67
  - Cancel All Watering . . . . .68
  - Adjust Screen (Run Time Percentage Adjust) . .69
  - Station Review Screen . . . . .69
  - Water Window Screen . . . . .72
  - Water Window Features . . . . .72
  - Watering Schedule Diagram . . . . .75
  - System Alarms . . . . .76
  - Utilities Screen . . . . .79
  - Wireline Setup Screen . . . . .80
  - Radio Setup Screen . . . . .81
  - Telephone Modem Setup Screen . . . . .83
  - Clear User Data . . . . .84
  - Satellite Monitor Screen . . . . .85
  - Check 1 Satellite Status Screen . . . . .86
  - Check 2 Program/Satellite Screen . . . . .87
  - Check 3 Program/Station Screen . . . . .88
- Appendix A: Troubleshooting . . . . .90**
- Appendix B: Specifications/Accessories/FCC Rules . . . . .91**
- Appendix C: Glossary . . . . .92**
- Data Worksheets (masters for copies): . . . . .95–96**

# Introduction To TouchNet

---

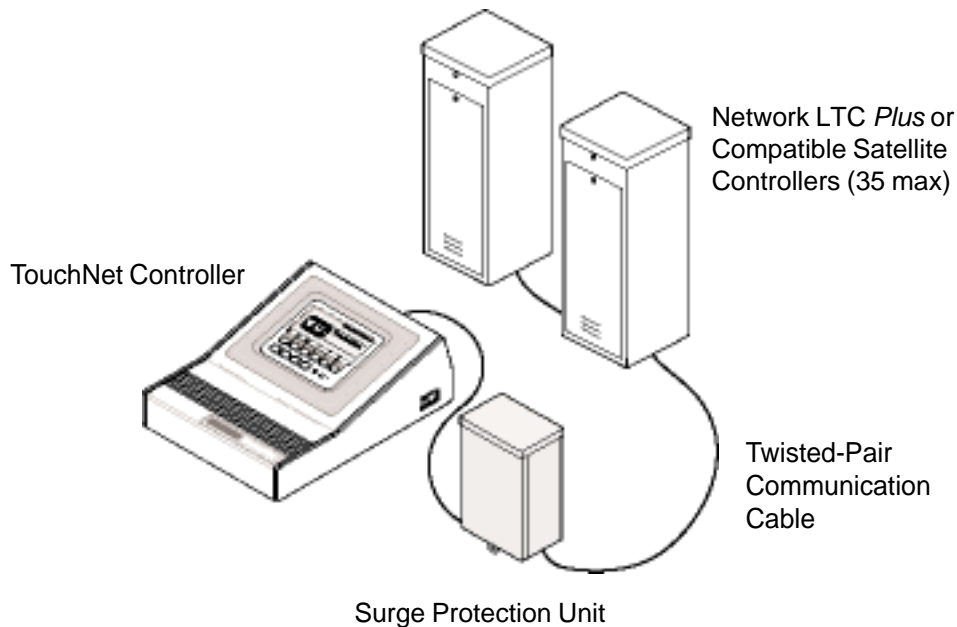

Welcome to TouchNet for Network LTC *Plus*, the easy-to-use central irrigation control system from The Toro Company.

You will find the TouchNet amazingly simple to use with its unique AcuTouch™ programming feature. All system programming and operation commands are easily made on intuitive, self-prompting screen displays.

The automated hydraulic flow management feature, HydroGuard™, protects your system from excessive flow demands and optimizes your system irrigation cycles for peak efficiency.

The illustration above, shows the basic components of the TouchNet control system utilizing twisted-pair communication cable. A heavy-duty Toro Surge Protection Unit is supplied to help safeguard the TouchNet from induced voltage spikes which may be incurred on the buried cable. The TouchNet is also supplied with the appropriate AC power adapter for connection to domestic or international power sources.

The TouchNet is also compatible with optional Radio and Telephone modem communication media. Refer to page 91 for optional accessory model numbers.

## TouchNet Features

- Manages up to 35 Network LTC and Network LTC *Plus* satellites
- Up to 8 irrigation programs
- Up to 8 switch programs (up to 2 per satellite)
- Up to 12 start sequences
- Programs and start sequences are user-definable and prioritized in any order
- 7-day calendar, 1- to 30-day interval or odd/even schedule
- User-specifiable day change time
- Provides true two-way communication for monitoring and feedback of satellite conditions, indicating on-line error status
- Adjustment factors simplify program refinement
  - 0-250%
  - system adjust for all stations
  - program adjust for select stations
- Extensive alarm capabilities
  - protects against user errors
  - alerts user to system communication errors
- HydroGuard™ hydraulic system management
  - up to 20 flow groups
  - protects hydraulic system
  - optimizes irrigation cycle
- Optional Network Hand-Held radio capability (Golf application only)
- Optional Radio-Link™ capability
- Optional Telephone modem capability (Commercial application only)

## About this manual...

Throughout the manual, two symbols are used to bring attention to helpful or very important points of information.



The **Note** symbol is used to highlight special information which is helpful to know about the installation, programming or use of the TouchNet control system.



The **Alert** symbol is used to highlight special points of information or procedures which are critical for the proper function, operation or safety of the TouchNet control system.

# Installation Procedure

## Installing the TouchNet and Surge Protection Unit

The TouchNet can be hung on the wall or simply positioned on a sturdy desktop. You may find the controller's touch screen more convenient to use in the desktop position by extending the swing-out legs located in the bottom of the cabinet assembly.



Under no circumstances should the TouchNet controller be installed outdoors or in an unprotected environment.

1. Plug the 2-wire interface cable connector (supplied) into the receptacle located on the back of the controller cabinet as shown in **Figure 1**.

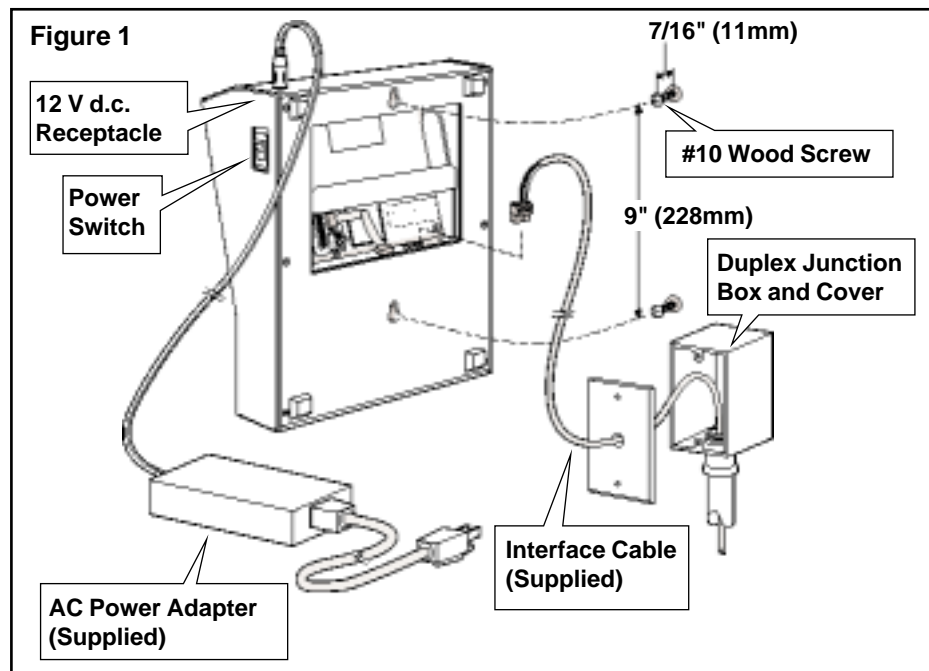

2. If installing the controller on the wall, install a #10 x 1.5" (38mm) wood screw (and plastic screw anchors if required) into the wall at eye level. Install a second screw 9" (228mm) directly below the top screw. Leave the screw heads extending from wall 7/16" (11mm).
3. Hang the controller on the screws using the keyhole slots. Ensure the controller is securely anchored to the wall.

## Installation Procedure – 2

4. With the TouchNet power switch in the Off position, plug the AC power adapter cord into the controller's 12 V d.c. receptacle. Plug the AC power adapter into the wall outlet using the power cord supplied. The power switch should remain Off until the installation has been completed.



For plugable equipment, the socket-outlet shall be installed near the equipment and shall be easily accessible.

5. To facilitate installation of the interface cable from the TouchNet to the Surge Protection Unit (SPU), install a standard duplex junction box with a single-hole cover plate as shown in **Figure 1**. Install conduit from the junction box to the intended location of the SPU.



Check local electrical codes regarding conduit requirements and install conduit accordingly.

6. A 20' (6.1m) length of interface cable is supplied. Select an outside installation site for the SPU within cable reach and 3' to 5' (0.9m to 1.5m) above ground level for straight and easy access to an earth ground.
7. Using the four mounting holes provided in the enclosure, attach the SPU enclosure securely to the wall using the appropriate screw fasteners/anchors. See **Figure 2**.

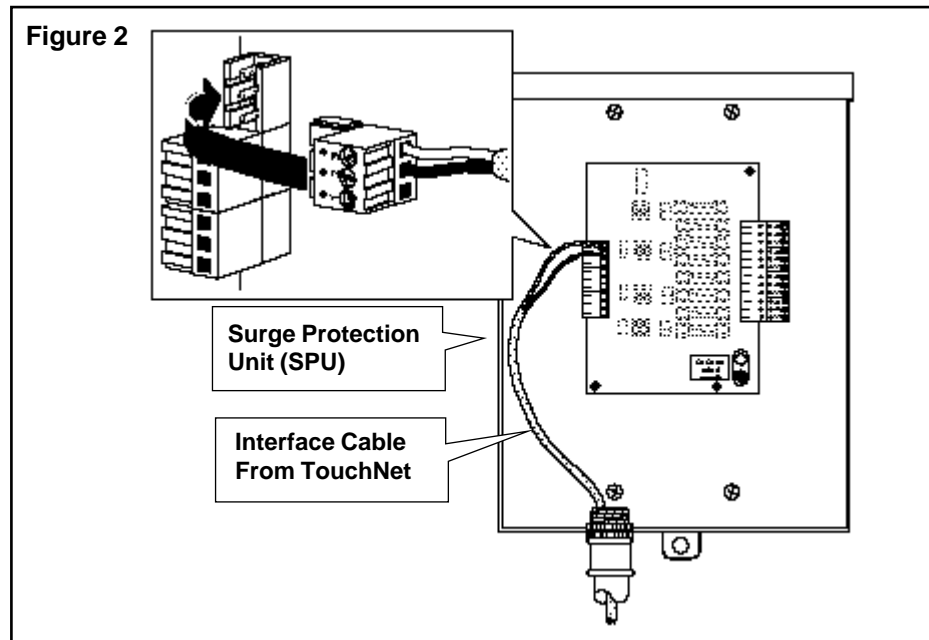

8. Install the conduit (routed from the duplex junction box) to the bottom left side of the SPU enclosure.
9. Pull the interface cable through the conduit from the TouchNet controller into the SPU.
10. Secure the black and white communication cable wires to the top connector plug on the left side of the SPU circuit board assembly as shown above.



## Installation Procedure – 2

### Installing an Earth Ground



An earth ground connection with a measured resistance of 10 ohms or less is recommended for all electrical components and power sources throughout the golf course. The TouchNet power source equipment ground and the SPU should be bonded to the same ground source. All satellite locations and pump station (if applicable) should be similarly grounded in an attempt to provide the same ground potential at all irrigation equipment sites throughout the golf course.



The following instructions depict one of several recommended grounding methods. The method shown may not be suitable for your installation site. Contact your local Toro distributor for alternate grounding methods and availability of the required earth ground resistance test instrument. Recommended ground testers are: AEMC Instruments, model 3710 clamp-on tester, or Biddle Megger, model 250260 (or equivalent).

1. Drive a 5/8" (16mm) by 8' (2.5m) copper-clad steel rod into well-moistened soil not more than 12' (3.6m) from the SPU.
2. Using a wire clamp or "CAD weld" fastener, attach a length of 6-gauge (6mm<sup>2</sup>) solid-core, bare copper wire to the ground rod. Route the wire through the small opening provided in the bottom of SPU cabinet and secure it to the ground lug. See **Figure 3**.

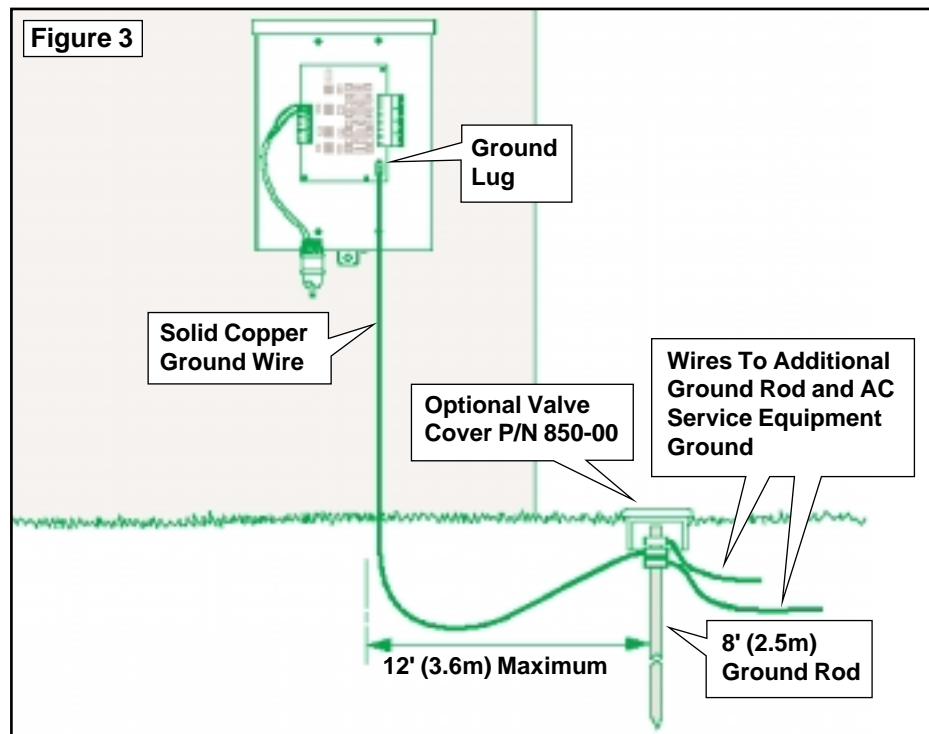

## Installation Procedure – 2

3. Measure the resistance at the SPU ground lug. A reading of 10 ohms or less is acceptable. If the resistance is more than 10 ohms, install an additional ground rod at a distance equal to twice the buried depth of the first rod. Connect the rods using 6 AWG (6mm<sup>2</sup>) bare copper wire and measure the resistance again.



If the resistance continues to exceed 10 ohms, contact your local Toro distributor for assistance and recommendations.

### Installing the Communication Cable

Shielded, twisted-pair communication cable must be used in this installation.



Please note the following cable installation requirements:

- The satellite is designed for use with shielded, twisted-pair, communication cable. Consult with your local Toro distributor for the cable type and wire size best suited for your installation.
- More than one cable run can be connected to the SPU.
- A satellite communication cable can emanate from another satellite connection.
- If additional communication cable runs are installed for future system expansion, each cable wire pair must be terminated with a 600 ohm resistor.
- If the communication cable is routed in the same trench as main power wires, a minimum of 12" (30.5cm) separation is recommended to prevent voltage induction on the communication cable. Check local codes for actual requirements.
- Refer to the installation instructions provided with the satellite controller for additional communication cable connection procedures.
- If in-ground cable splices or repairs are required, the connection must be properly insulated with a waterproof splicing device. Using an appropriate splicing kit, such as Scotchcast 82-A1 (or equivalent), is recommended. Placing the cable splice in a small valve box for protection and accessibility is also recognized as good installation practice.

## Installation Procedure – 2

1. Route the communication cable(s) from the SPU to the satellite locations as shown in **Figure 4**.

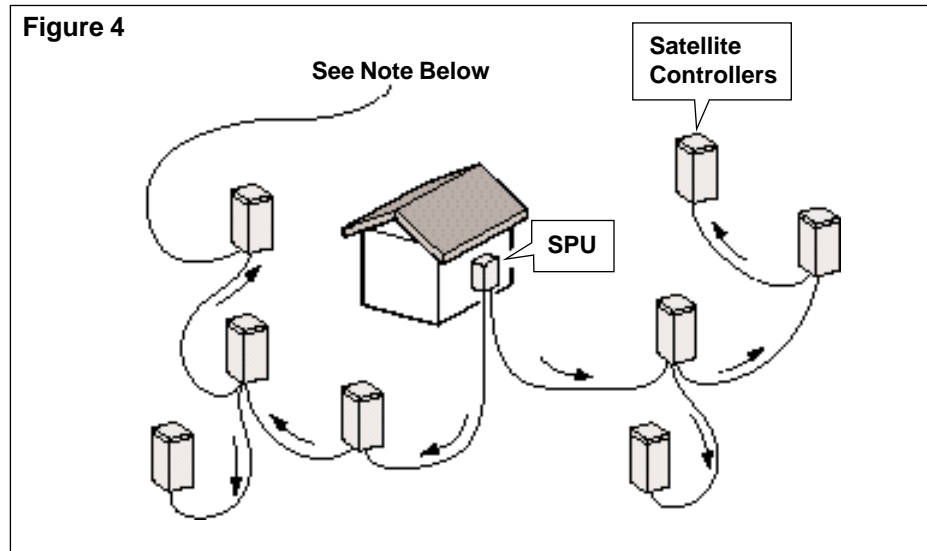

If additional communication cable runs are installed for future system expansion, each twisted-pair cable must be terminated with a 600 ohm resistor as shown **Figure 4A**.

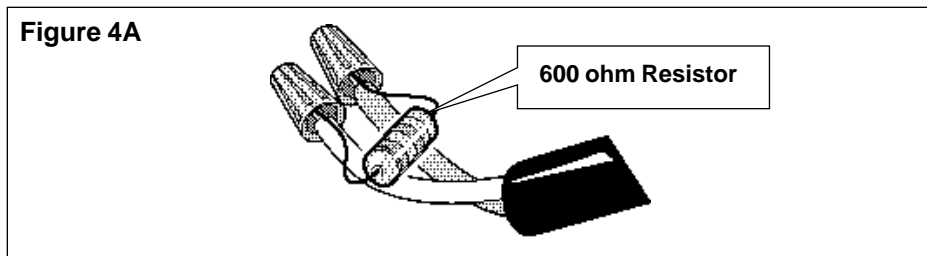

## Installation Procedure – 2

2. Pull approximately 18" (45.7cm) of cable into the SPU.
3. At the SPU, remove 18" (45.7cm) of the cable outer jacket. Remove the inner wrapping to expose approximately 16" (40.6cm) of communication and drain wires. Strip 3/8" (9.5mm) of insulation from the communication wires. See **Figure 5**.

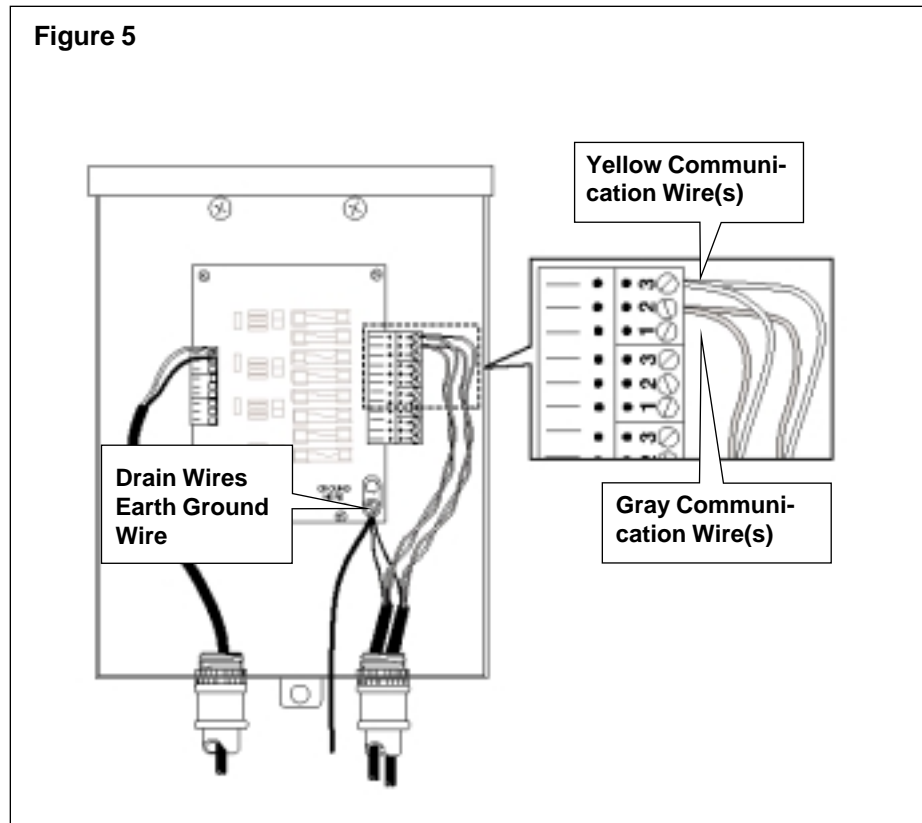

4. Secure the yellow and gray communication wires to the top connector plug on the right side of the SPU circuit board assembly as shown in **Figure 5**. If more than one cable run is used, install matching wire colors to the same connector plug.
5. Secure the drain wires to the copper ground lug with the earth ground wire.



Do not attach the communication wire connector plugs to the satellite modems until proper communication cable installation has been verified using the following test procedure.

### Testing The Communication Cable

Correct installation of the communication cable is essential for proper operation of the TouchNet system. The communication cable must be tested for the presence of significant voltage, circuit continuity and excessive resistance. A digital multimeter and a 600 ohm resistor are required to perform the following tests.

- A. Remove the communication wire connector plug at the SPU.
- B. Test for the presence of voltage on the communication and drain wires as follows:

Connect the positive lead of the voltmeter to either end of a wire circuit and the negative lead to an earth ground. If the voltmeter indicates more than one volt, connect a 600 ohm resistor between the open end of wire circuit and earth ground. Perform the voltage test again. If the voltage drops to less than one volt, the condition is acceptable. If the reading exceeds one volt, it may be due to a direct connection or induced if the communication cable is run with the power wires. A minimum spacing of 12" (30.5cm) is required between the communication cable and power wires. Locate the source of power and correct before continuing.
- C. Test the communication and drain wire circuits for possible cross connection (yellow connected to gray, etc.). Perform the test as follows:

Connect one Ohmmeter lead to each communication wire; the Ohmmeter should indicate an open circuit. If the Ohmmeter indicates a complete circuit, check the communication wire connector plug at each satellite controller location for a possible crossed connection. When the wire circuit has been corrected and/or tested successfully, continue to the next step.
- D. Test the communication and drain wire circuit for continuity and total resistance. Perform test as follows:

At the furthest satellite controller location, install a jumper wire across the communication wires. At the SPU, touch the Ohmmeter leads to the signal wire connector plug. If the circuit continuity is good, the Ohmmeter will indicate some resistance. Record the resistance (ohms) reading for future reference. If the circuit is open (no resistance), check the communication wire connector plug at each satellite location for loose or improperly installed wires. When the circuit has been tested successfully and resistance recorded, remove the jumper wire and replace with a 600 ohm resistor.

## Installation Procedure – 2

E. Determine if the measured resistance of the communication wire circuit is less than or equal to the maximum allowable resistance. The allowable resistance of 16 AWG (1.0mm<sup>2</sup>) signal wire is 7 Ω (Ohms) per 1000' (305m). The allowable resistance of 18 AWG (0.75mm<sup>2</sup>) signal wire is 11 Ω per 1000' (305m). Calculate the resistance as follows:

Divide the length of the circuit by 1000' (305m). Multiply the quotient by 7 for 16 AWG (1.0mm<sup>2</sup>) wire or 11 for 18 AWG (0.75mm<sup>2</sup>) wire. The product is the maximum allowable resistance for the circuit.

**Example: Total length of 16 AWG (1.0mm<sup>2</sup>) wire circuit is 3500' (1067m)**

$$3500' (1067 \text{ m}) \div 1000' (305 \text{ m}) = 3.5$$

$$3.5 \times 7 \Omega = 24.5 \Omega$$

F. Compare the actual circuit resistance measured in Step D with the calculated allowable resistance. If the actual resistance exceeds the maximum allowable, check the cable for damage and/or a possible break. Also check the connector plug at each satellite for loose or improperly installed wires. If the actual resistance is less than or equal to the allowable resistance, the circuit is properly installed. When both wire circuits have been tested successfully, reconnect the communication cable connector plug at the SPU and at all satellite locations.

# Getting Started

---

## About the System Type Screen

When the TouchNet controller is first powered-up, or has been re-initialized, you will see the System Type screen as shown in **Figure 6** below. This screen, which appears only once, is used to select the type of irrigation system application: Golf or Commercial. The major difference in the two types of systems is the predefined program names and the optional use of telephone communication between the TouchNet and field satellite controllers.

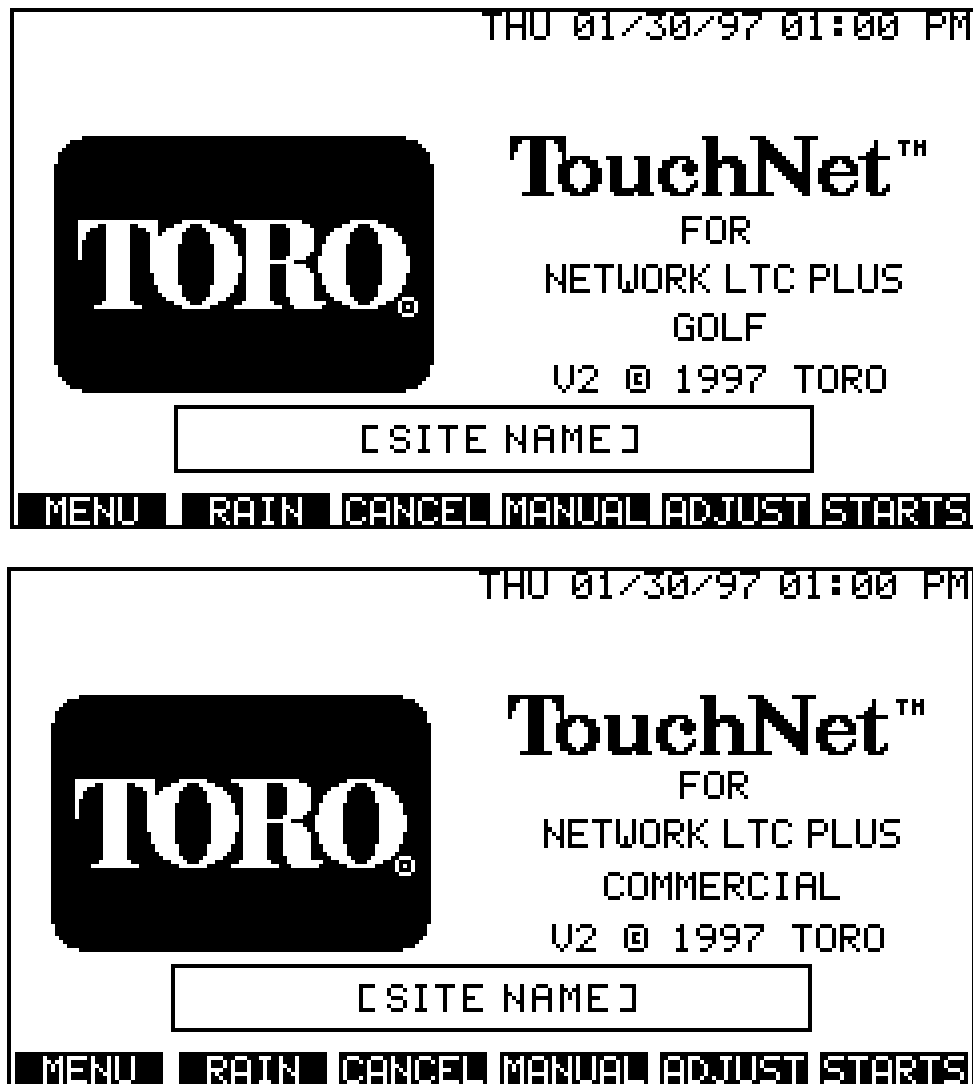

**Figure 6** - System Type screen.

Touch the the Golf or Commercial system type. Touch OK to exit this screen. The Home screen will appear next as shown in **Figure 6A**.



If you wish to change the system type, the TouchNet must first be re-initialized. See the “Clear User Data” procedure located in the “Utilities Screen” section starting on page 79.



**Figure 6A** - Home screens for Golf and Commercial .

The Home screens for both the Golf and Commercial systems are shown above in **Figure 6A**. Only the home screen of the system type you have selected will be displayed. Touching the Site Name box on the home screen enables you to enter any name (up to 18 characters) that you choose using the pop-up display keypad. For information on using pop-up keypads, see “Using the Pop-up Keypads” page 14.

As you navigate through the various TouchNet screen displays, you can return to the Home screen through the MENU screen by touching the TORO key in its lower left corner.



The “No Watering” icon  will appear above the Toro Logo on the Home screen to alert you that irrigation has been placed on Rain Delay, canceled or the field satellites have been placed in the “Off” mode by the TouchNet.



## The Function Keys

The Home screen has no active programming controls, but does provide six standard function keys. These function keys are found on most screen displays and enable you to quickly navigate to the most commonly used system control functions.

The following is a brief description of each function key. For detailed information, refer to the appropriate section in the User's Guide.

### MENU

Touch MENU to navigate to the main Menu screen shown in **Figure 7**. This provides access to the TouchNet submenus: Setup, Hydraulics, Programs, Starts, Satellites, Stations, Adjust, Water Window, Sat (Satellite) Monitor, Manual, Alarms, Switch Programs and Utilities.

MENU			FRI 06/21/96 01:01 PM		
SETUP	SATELLITES	MANUAL			
HYDRAULICS	STATIONS	ALARMS			
PROGRAMS	ADJUST	SWTCH PRGMS			
STARTS	WATER WINDOW	UTILITIES			
	SAT MONITOR				
TORO RAIN CANCEL MANUAL ADJUST STARTS					

Figure 7 - Menu screen.

### TORO (Visible from Menu screen only)

Touch TORO on the Menu screen to return to the Home screen.

### RAIN

Touch RAIN to bring up the keypad that allows you to activate the Rain Delay feature. You can place a hold on future irrigation either permanently or for a specified period of time. Refer to Section 7, "Special TouchNet Features" for specific feature information.

### **CANCEL**

Touch CANCEL to stop all current and scheduled irrigation for the active day. Normal watering operations are started again when a new calculation and subsequent downloading of the watering schedule is done. This can be done manually from the Water Window screen, or at the scheduled Auto Download time (defined on the Setup screen).

### **MANUAL**

Touch MANUAL to navigate to the Manual screen. From here you can enter instructions to start watering programs manually.

### **ADJUST**

Touch ADJUST to go to the Adjust screen. This screen allows you to enter a percentage that will adjust the watering time at the irrigation system level, program level or both. Note that the Adjust feature does not apply to Switch programs.

### **STARTS**

Touch STARTS to move to the Starts screen. On this screen you enter the start time, priority data and access the Set Watering Days screen for the irrigation programs.

### **Using the Pop-up Keypads**

Programming the TouchNet is easy with the unique AcuTouch™ feature. You will enter data into the controller using pop-up keypads. The most common is the numeric keypad shown in **Figure 8**. This is mainly used to input rain delay days, times, dates and other numeric data.

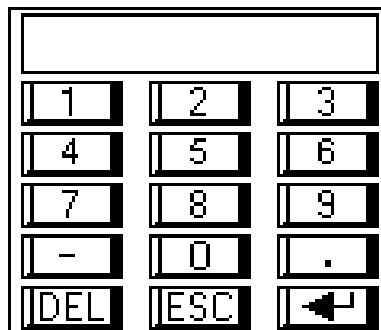





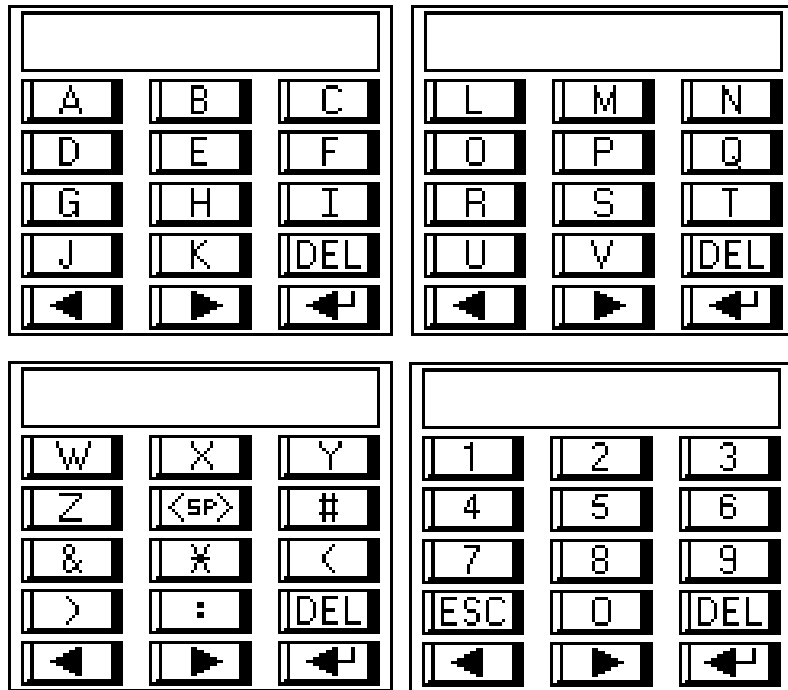

**Figure 8** - Numeric pop-up keypad.

When you need to enter names of programs, satellites and other information that uses letters, the alpha-numeric keypads are displayed as shown in **Figure 9** on the following page. This is a group of keypads that gives you the full alphabet, numbers and other characters in a series of four pop-up displays.



**Figure 9** - Series of alpha-numeric pop-up keypads.

-  The **Space** key is used to place a blank space between characters.
-  The **Delete** key is used to remove characters, one at a time, that have been entered on the keyboard.
-  The **Escape** key is used to exit the current keypad without accepting your data entry. This either brings you to the next keypad prompt or returns you to the underlying screens.
-  Touch the **Enter** key to place the information selected on the keypad into the TouchNet memory.
-  The **Right Arrow** key allows you to scroll to the next keypad in the series. If you are already at the last keypad, pressing this button automatically brings you to the first keypad.
-  The **Left Arrow** key lets you scroll to the previous keypad in the series. If you are at the first keypad, touching this button scrolls you backward to the last keypad.



On all keypads, the display area at the top provides a message prompt with the information that needs to be entered.

## Other Buttons on the TouchNet

The TouchNet also has a set of raised function buttons below the touch screen. Each button will initiate the same action as the on-screen function immediately above it.

The four raised buttons at the bottom of the panel function as follows: The ▲ and ▼ buttons are provided for future use and are not functional at this time. The ► Delete and ◀ Enter buttons duplicate the actions of the Delete and Enter keys on the pop-up keypad.



The TouchNet can be fully programmed and operated using only the touch control areas on the screen display.

## Configuring the Controller

To configure the TouchNet controller for operation, you will need to enter some basic information about your irrigation system. This will enable TouchNet to accurately calculate and optimize water flow throughout the system. Begin by going to the Menu screen.

## The Menu Screen

The Menu screen is the starting point for accessing virtually all configuration, programming, operation and system information screens available for your TouchNet controller.

To quickly access the TouchNet Menu screen shown in **Figure 10**, touch the MENU function key located on the bottom left corner of the Home screen. To return to the Home screen, touch the TORO key.

MENU		FRI 06/21/96 01:01 PM	
SETUP	SATELLITES	MANUAL	
HYDRAULICS	STATIONS	ALARMS	
PROGRAMS	ADJUST	SWTCH PRGMS	
STARTS	WATER WINDOW	UTILITIES	
	SAT MONITOR		
TORO	RAIN	CANCEL	MANUAL ADJUST STARTS

Figure 10 - Menu Screen.

## System Setup

To start configuring the controller, select the Setup screen from the Menu screen by touching SETUP. The Setup screen will appear as shown in **Figure 11**.

SETUP		FRI 06/27/97 01:02 PM							
TIME	1:02 PM	MODE							
DATE (M/D/Y)	06/27/97	MODE							
DAY CHANGE	6:00 AM								
AUTO DNLOAD?	YES <input checked="" type="radio"/> NO <input type="radio"/>	TIME: 4:00 PM							
FLOW UNITS	GPM	SAT	CENT						
		LOCK	NO						
<table border="1"> <tr> <td>MENU</td> <td>RAIN</td> <td>CANCEL</td> <td>MANUAL</td> <td>ADJUST</td> <td>STARTS</td> </tr> </table>				MENU	RAIN	CANCEL	MANUAL	ADJUST	STARTS
MENU	RAIN	CANCEL	MANUAL	ADJUST	STARTS				

**Figure 11** - The Setup screen.



Most of the screen examples shown throughout this manual have information entered to depict typical programming entries. The actual screens, when selected, will have only default information entered and will therefore appear differently than shown in the examples.

On this screen you will enter your general system information and the overall operating parameters of your system.

### Set Current Time

The first item to be set is the current time. The current time and date are displayed in the upper right corner of all screens.

#### To enter the current time...

- Touch the box displaying the time. A pop-up keypad is displayed with the “Hours” prompt.
- Select the current hour by touching the number(s).
- Touch the **Enter**  key to enter the hours and activate the “Minutes” prompt.
- Set the minutes the same way you set the hours.

#### If the system is in the 12-hour (a.m./p.m.) mode...

- A third prompt appears, “1=AM, 2=PM”
- Touch “1” for AM
- or -
- Touch “2” for PM.
- Touch the **Enter**  key.

### Remember...

- If you make a mistake, touch **DEL** to erase characters one at a time.
- Touch **ESC** to exit the current screen without making any changes to the TouchNet memory.
- Touch **Enter**  after changing or entering data to update the TouchNet memory.



If you attempt to enter information into TouchNet which cannot be accepted, you will be prompted by the message “Bad Input”. For example, if “0” was entered for the AM/PM prompt, “Bad Input” would appear. A valid number could then be selected.

### Select Time Mode

To set the clock to a 24-hour time mode, press the MODE box next to the TIME display. The clock mode is automatically converted. Touching this box toggles between the 12-hour and 24-hour time modes. The default is 12-hour.

### Set Current Date

Next, you will want to set the current date which is displayed next to the time in the upper right corner of all TouchNet screens.

#### To set the date...

- Touch the box displaying the date. A pop-up keypad is displayed with the “Year” prompt.
- Enter the current year by touching the numbers.
- Touch the **Enter**  key to enter the year and activate the “Month” prompt.
- Set the month and the day the same way you set the year.

### Select Date Display

To change the date display from Month/Day/Year (M/D/Y) to Day/Month/Year (D/M/Y), press the MODE box next to the DATE display. Touching this box toggles between the two displays. The default is M/D/Y.

### Set Day Change Time

A calendar day, which changes at 12:00 a.m. (0:00) midnight, may be inconvenient for golf course irrigation scheduling because watering is usually required for some time before and after midnight. The Day Change time option allows the watering day to be shifted forward or backward so all watering required per day can then be completed without a calendar day change occurring during operation.

For example, if watering is required for 10 hours, beginning at 7:00 p.m. (19:00) and ending at 5:00 a.m. (5:00), the Day Change time could be set to 6:00 a.m. (6:00) which would enable all watering to be completed in one (watering) day.

### To set the Day Change time...

- Touch the Day Change box to bring up the pop-up menu with the “Hours” prompt.
- Enter the desired day change time the same way as the current time was input.

### For example, to set the Day Change time to 7:00 a.m.:

- Touch the display box next to DAY CHANGE.
- Touch “7” for the “Hours” prompt and touch **Enter** ↵ .
- Touch “0” twice for the “Minutes” prompt and press the **Enter** ↵ key again.
- If the clock is in the 12-hour time mode, touch “1” for a.m. and press **Enter** ↵ .



When selecting a Day Change time, a system alarm will occur if the day change time occurs **before** the Watering Cycle End time. Refer to “System Alarms,” page 76 and “The Water Window Screen,” page 72 for additional information.

### Automatic Download

TouchNet’s automatic download feature enables all adjustments made to the irrigation programs to be automatically calculated for the active watering day and communicated to the satellites at a predetermined time.



The Automatic Download time should be set to a minimum of one hour prior to the earliest Watering Sequence Start time. This enables the TouchNet to perform the required calculations and enables you to make any necessary adjustments to the watering schedule before watering begins. Refer to “The Water Window Screen,” page 72 for more information.

Auto download time is preset for 4:00 p.m. (16:00). To change the time, use the following procedure.

### To set automatic download...

- Touch **Yes**.
- Set the time you wish the download to occur by following the prompts on the pop-up keypads.

When Auto Download is selected, the YES circle is darkened and the download time you set is displayed in the field to the right of the YES/NO boxes.

Typically, you will want to use the Auto Download feature. If you do not want TouchNet to calculate and download watering program information automatically, select **No**. The warning screen, shown in **Figure 12**, will be displayed. (See “Download to Satellites,” page 74 for more information on manual downloading.)

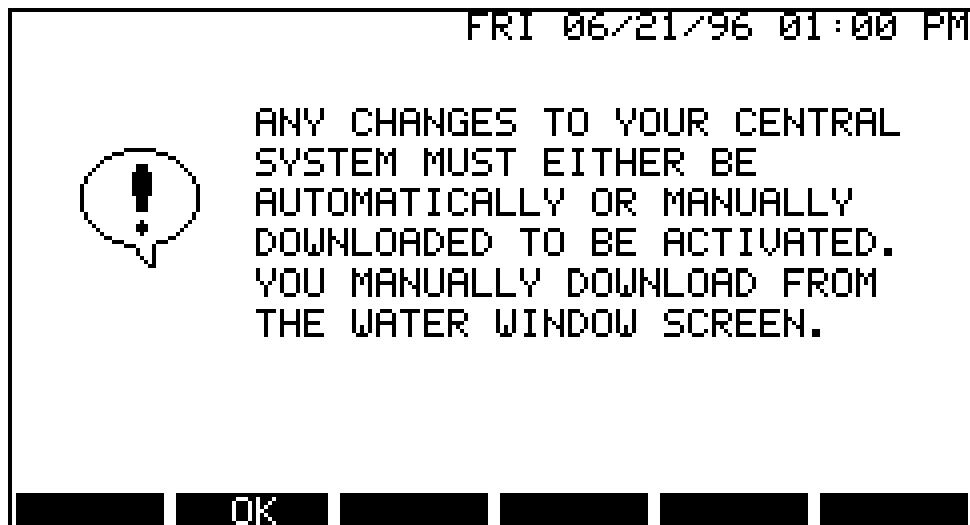

**Figure 12** - The Download warning screen.

### Set Flow Units

TouchNet can be programmed to operate in either GPM (Gallons Per Minute) or LPM (Liters Per Minute) measurement systems. The default value is GPM. To toggle between GPM and LPM, touch the box next to FLOW UNITS.

The Flow Units selected on this screen will be displayed on all screens where flow units are shown.



The Flow Units option is used as a label only and has no unit measurement conversion function. Selecting the alternate flow units will not convert the equivalent numeric values from one measurement system to the other. For example, 100 GPM will be displayed as 100 LPM if the flow units are changed from GPM to LPM.



### Satellite Mode

Touch the box next to SAT to choose one of three satellite modes: Off, Central, or Stand Alone. Each touch toggles to the next mode.

#### OFF

When the satellite mode is set to OFF, the programs stored in the satellite will not run, even though power to the unit is on. As a reminder of this condition, the “No Watering” icon will be displayed in the upper left corner of the Home screen.

#### CENT (Central)

This is the default setting and the mode used most often. When set to CENTRAL, the satellites are controlled from the TouchNet controller.

#### STDALN (Stand Alone)

When the satellite mode is set to STDALN (Stand Alone), each satellite in the field is controlled by its own internal memory. Use this setting if you need to take TouchNet off-line for any reason.

### Satellite Lock

Located below the satellite mode is the LOCK display. Touch the box to toggle between YES and NO. The default setting is NO (unlocked).

- **YES**

Selecting YES locks the satellites to the TouchNet central and prevents programming via the satellite timing mechanism. Manual operation at the satellites is not affected by the lock condition and is still allowed via the satellite timing mechanism.

- **NO**

Selecting NO toggles off the lock feature.

The following information is communicated to the satellites when it is entered onto the touch screen: Time, Date, Day Change, Satellite Mode and Satellite Lock. The remainder of the information is sent to the satellites when the system download occurs.



The time required to the TouchNet to communicate with the satellites will vary with the communication medium ( wireline, telephone modem or radio) being used.

This completes the general setup procedure. Return to the Menu screen by touching the MENU key. See “Programming the Controller” for step-by-step instructions on programming the TouchNet for operation.

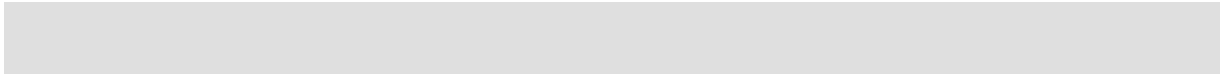

**Notes:**

# Programming the Controller

---

Once you have completed the initial setup, you are ready to begin programming TouchNet to control irrigation for your site. You need to enter information about your irrigation system which will enable the TouchNet to accurately calculate and optimize water flow and perform irrigation functions.

You will need to have the following system information on hand before you start:

- An “as-built” plan of the irrigation layout showing sprinklers piping and satellites.
- Completed TouchNet System and Satellite Field Data worksheets. (A master worksheet has been provided in the back of the manual so photocopies can be easily made.)
- Watering areas on the plan, broken down into Flow Groups (20 maximum).
- Total system flow.
- Maximum flow rate of each Flow Group.
- Maximum flow rate of each satellite station.
- Optimum run time of each satellite station.

## **Items to Keep in Mind...**

Stations can be grouped together and assigned to programs for the purpose of making adjustments easy. The programs can be given names such as Greens, Tees etc. for a golf application or Turf, Shrubs, etc. for a commercial site. For example, a program called “Greens” could control stations/sprinklers that water the greens in a Flow Group.

For each irrigation program (8 maximum) you will need to record the irrigation function in addition to the run time and flow rate of the majority of stations which will be assigned to that program. This data will be the default values entered during the programming procedure.

Starting on page 24, you will find an example of a typical golf course system (**Figure 13**) and an example of the completed worksheets (**Figures 14** and **15**). If you have selected the golf programming system, continue to the next page. If you are programming the TouchNet for a commercial application, begin the programming steps on page 42.

## Golf Course Layout Example

Figure 13

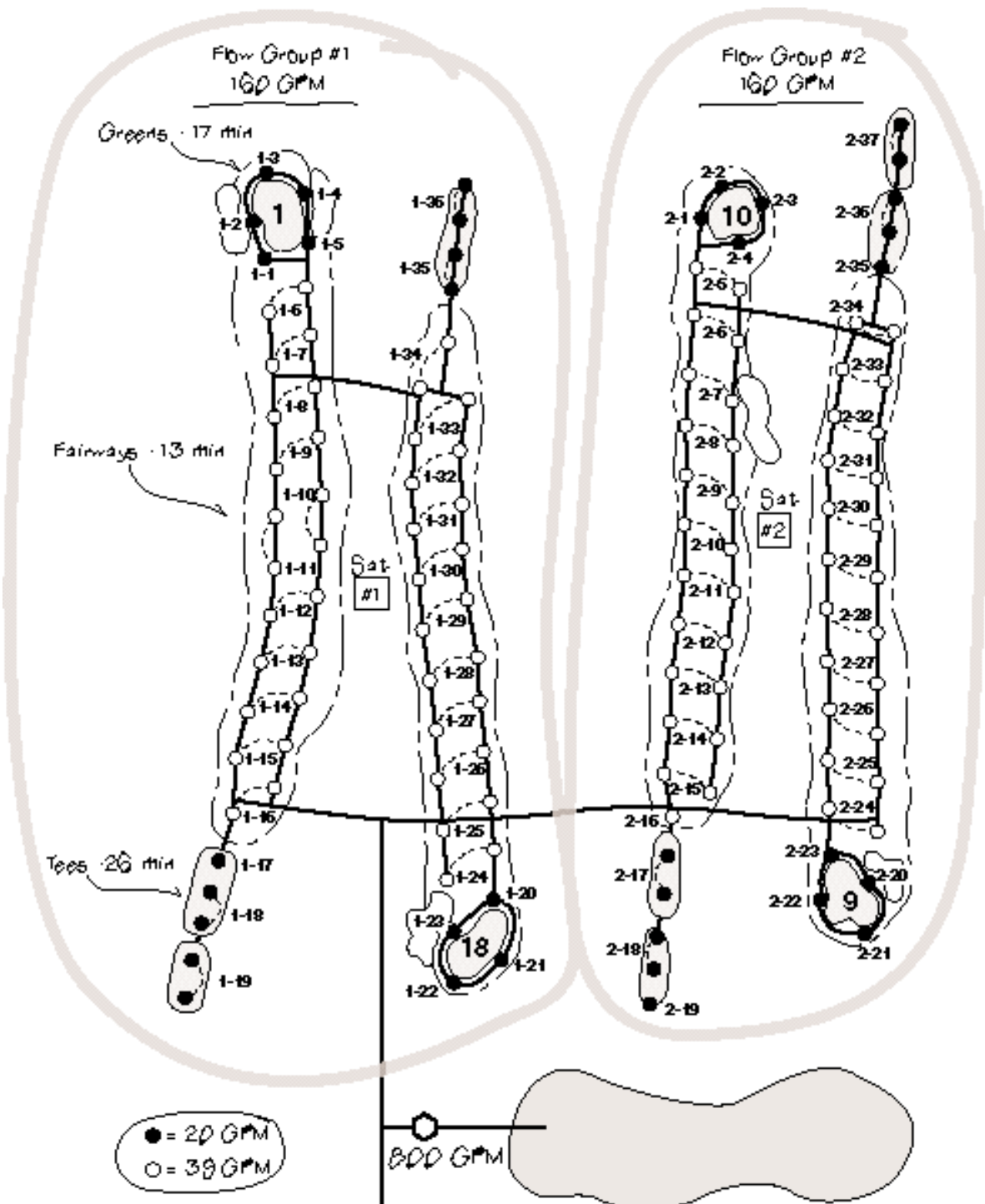



# Programming the Controller (Golf) – 4

Figure 15

## Network LTC™ Satellite Field Data Worksheet

<b>Satellite No.</b>	1
<b>Name/Area</b>	Holes 1 and 18
<b>Max Sim Pgms</b>	3
<b>Flow Group</b>	1

Switch Program #	Start Times			
	Start 1	Start 2	Start 3	Start 4
Switch 1	5:00 a.m.			

Sta.	Program	Time	Flow	Group
1	Greens F9	17	20	1
2	Greens F9	17	20	1
3	Greens F9	17	20	1
4	Greens F9	17	20	1
5	Greens F9	17	20	1
6	Fairways F9	13	78	1
7	Fairways F9	13	78	1
8	Fairways F9	13	78	1
9	Fairways F9	13	78	1
10	Fairways F9	13	78	1
11	Fairways F9	13	78	1
12	Fairways F9	13	78	1
13	Fairways F9	13	78	1
14	Fairways F9	13	78	1
15	Fairways F9	13	78	1
16	Fairways F9	13	78	1
17	Tees F9	26	40	1
18	Tees F9	26	40	1
19	Tees F9	26	40	1
20	Greens B9	17	20	1
21	Greens B9	17	20	1
22	Greens B9	17	20	1
23	Greens B9	17	20	1
24	Fairways B9	13	78	1
25	Fairways B9	13	78	1
26	Fairways B9	13	78	1
27	Fairways B9	13	78	1
28	Fairways B9	13	78	1
29	Fairways B9	13	78	1
30	Fairways B9	13	78	1
31	Fairways B9	13	78	1
32	Fairways B9	13	78	1

Sta.	Program	Time	Flow	Group
33	Fairways B9	13	78	1
34	Fairways B9	13	78	1
35	Tees B9	26	40	1
36	Tees B9	26	40	1
37				
38				
39				
40				
41				
42				
43				
44				
45				
46				
47				
48	Switch 1	12 hrs		
49				
50				
51				
52				
53				
54				
55				
56				
57				
58				
59				
60				
61				
62				
63				
64				

## Programming the Controller (Golf) – 4

### System Hydraulics Setup

To begin, you will need to define your irrigation system hydraulic capacities (limits). The Hydraulics screen allows you to specify maximum flow for the system and the maximum flow for each flow group.



Entering accurate information on the Hydraulics screen is essential for proper operation of the HydroGuard flow management system.

The HydroGuard flow manager ensures that system flow capacity is utilized at peak efficiency throughout the watering cycle. This results in the maximum amount of water being supplied in the minimum amount of time, while protecting the system and defined Flow Groups from excessive flow conditions.

HYDRAULICS		TUE 02/27/96 01:03 PM	
SYSTEM FLOW	<input type="text" value="800"/>	GPM	
FLOW GROUP 1	<input type="text" value="160"/>	GPM	
FLOW GROUP 2	<input type="text" value="160"/>	GPM	
FLOW GROUP 3	<input type="text" value="120"/>	GPM	
FLOW GROUP 4	<input type="text" value="160"/>	GPM	
MENU RAIN CANCEL MANUAL <<FGRP FGRP>>			

Figure 16 - The Hydraulics Screen showing System and Group flow values.

### Setting up the hydraulic values...

- Select the HYDRAULICS box from the system Menu screen. The Hydraulics screen will appear as shown in **Figure 16**.
- Touch the box adjacent to SYSTEM FLOW.
- Use the pop-up keypad to enter the flow capacity of your irrigation system (3,000 GPM [12,000 LPM] maximum).
- Enter the flow limit for each Flow Group (1–20) in the same manner.

Only four Flow Groups can be displayed at one time on the Hydraulics screen. To scroll forward through the group list, touch the **FGRP>>** key. To scroll backward, touch the **<<FGRP** key.

# Programming the Controller (Golf) – 4

When you are finished entering the flow rate data, return to the Menu screen by touching the MENU key.

## Watering Program Setup

The next step is to define the operating information for each watering program.

Touch PROGRAMS from the system Menu screen. The Programs screen will appear as shown in **Figure 17**.

	NAME	TIME	GPM
PGM 1	PROGRAM 1	0:00	0
PGM 2	PROGRAM 2	0:00	0
PGM 3	PROGRAM 3	0:00	0
PGM 4	PROGRAM 4	0:00	0
	REPEATS / SOAK TIME		

MENU RAIN CANCEL MANUAL << PGM PGM >>

Figure 17 - The Programs screen.

### The Programs screen enables you to...

- Change the name of each program
- Define a general run time and flow rate for each program
- Define a soak time and the number of repeat cycles for each program



The run time and flow rate information entered on the Programs screen can be transferred to the Stations screen to expedite station programming. It is important to remember that the Programs screen data is not dynamically linked to the satellite Stations screen. In other words, the information entered on the Programs screen will not automatically enter or update the information on the Stations screen. The run times and flow rates entered on the Programs screen will provide a general starting point for station programming and can be fine-tuned on the Stations screen.

### Naming Programs

By default, the programs are named Program 1, Program 2, etc. If you choose to rename a program, you may select one of 14 names already provided in the TouchNet memory, or you may



## Programming the Controller (Golf) – 4

rename the programs as you wish utilizing up to 12 characters and spaces for each name.

### To rename a program...

- On the Programs screen, touch the Name box of the program you wish to rename. The Program Names screen appears, as shown in **Figure 18**.

PROGRAM NAMES			WED 03/06/96 01:00 PM		
GREENS	F9	GREENS	B9	TEES	F9
TEES	B9	FAIRWAYS	F9	FAIRWAYS	B9
ROUGHs	F9	ROUGHs	B9	APPRCHS.	F9
APPRCHS.	B9	PERIMETR5	F9	PERIMETR5	B9
DRIVING RGE.		PUTTNG GREEN		OTHER	
SELECTD PGM->	GREENS	F9	SPELL IT OUT		
OK		ESCAPE			

Figure 18 - Program Names screen.

- Touch a listed name to select it. The name will be displayed next to "SELECTD PGM" (selected program).
- Touch the **OK** key to complete the selection, or touch the **ESCAPE** key to exit the Program Names screen without any changes being made.
- To type in a name, Touch the SPELL IT OUT box.
- Enter the name (up to 12 characters/spaces) using the pop-up keypads.



To type a space in the name, use the <SP> key provided on the third keypad.

- Touch the Enter key. The Program Names screen will appear and the new program name will be displayed next to "SELECTD PGM".
- Touch the **OK** key to complete the selection, or touch the **ESCAPE** key to exit the Program Names screen without any changes being made.
- The Programs screen will appear with the program name you selected.
- Repeat the process as needed for each program.
- Use the **PGM>>** or **<<PGM** keys to access additional programs.

# Programming the Controller (Golf) – 4

## Setting Program Run Time and Flow

In addition to assigning a program name, you can define the default station run times and station flow rates for each program. As mentioned previously, this data can be transferred to the Satellite Stations screen as default information to expedite the programming process. Therefore, you should enter the run time and flow rate which will be used for the majority of stations the program will be assigned to.

### To set program run times...

- Touch the TIME display box for the desired program.
- Follow the prompts on the pop-up keypad to enter the run time. (8 hours, 59 minutes maximum.)

### To set program flow rates...

- Touch the GPM (LPM) display box for the desired program.
- Follow the prompts on the pop-up keypad to enter the flow rate. (3,000 GPM or 12,000 LPM maximum.)



The program flow rate must not exceed the System and/or Group flow limits. A system alarm will be generated if this occurs.

PROGRAMS		TUE 02/27/96 01:04 PM	
	NAME	TIME	GPM
PGM 1	GREENS F9	0:17	20
PGM 2	GREENS B9	0:17	20
PGM 3	TEES F9	0:26	40
PGM 4	TEES B9	0:26	40
REPEATS / SOAK TIME			
MENU RAIN CANCEL MANUAL << PGM/PGM >>			

Figure 19 - The Programs screen with program names, run times and flow values defined.

## Programming the Controller (Golf) – 4

### To set Repeats/Soak times...

- Touch the REPEATS/SOAK TIME box on the bottom of the Programs screen. The Repeats/Soak-Time screen appears as shown in **Figure 20**.
- Touch the SOAK TIME display box for the desired program.
- Enter the number of minutes (0–59 minutes) using the pop-up keypad.
- Touch the REPEATS display box for the desired program.
- Enter the number of repeats (0–3) using the pop-up keypad.

REPEATS/SOAK-TIME TUE 02/27/96 01:04 PM				
	NAME		SOAK TIME	REPEATS
PGM 1	GREENS	F9	0:30	1
PGM 2	GREENS	B9	0:30	1
PGM 3	TEES	F9	0:15	1
PGM 4	TEES	B9	0:15	1
RUN TIME/FLOW VOL.				
MENU RAIN CANCEL MANUAL << PGM/PGM >>				

**Figure 20** - The Repeats/Soak-Time screen with program soak time and repeats defined.

When finished, you can touch the RUN TIME/FLOW VOL box to toggle back to the Programs screen, or you can touch MENU to return to the Menu screen.

Having defined the programs, the next step is to enter specific operating information for each satellite.

# Programming the Controller (Golf) – 4

## Satellite Setup

Select SATELLITES from the system Menu screen. The Satellites screen will appear similar to **Figure 21**.

SATELLITES		FRI 06/20/97 01:05 PM	
SATELLITE #		1..... X	
<b>WIRE</b>	<b>RADIO</b>		
NAME/AREA	HOLES 1 & 18		
STATIONS	32		
MAX SIM PGMS	3		
FLOW GROUP	1		
<b>MENU</b>		<b>RAIN</b>	<b>CANCEL</b> << <b>SAT</b> <b>SAT</b> >> <b>STAS</b>

Figure 21 - Satellites screen defined for example satellite #1.

The TouchNet has the capability of communicating with 35 unique satellite addresses which consist of a two-digit number from 1 to 35. Each satellite in the system must be assigned to one of the address numbers to enable communication with the TouchNet. The satellite specifications required by the TouchNet are entered on the Satellites screen.

### For each satellite, the Satellites screen allows you to...

- Define the method of central/satellite communication
- Customize the satellite name
- Define the number of stations installed
- Define the maximum number of programs that can run simultaneously when controlled by the TouchNet
- Define the Flow Group assignment
- Enable and disable communication from/to the TouchNet



The first time the Satellite screen is displayed, it will show Satellite # 1 information. To select a different satellite, touch the <<**SAT** or **SAT**>> keys.

### Communication Method

Wireline is the default method of communication. Radio communications requires optional hardware installation to be utilized. Refer to the instructions provided with the optional Radio Link installation kit for detailed information.

### Name/Area

The Name/Area option allows you to rename the satellite as you choose. The satellites are pre-named Satellite 1, Satellite 2, etc.

# Programming the Controller (Golf) – 4

## To enter a name...

- Touch the display box next to NAME/AREA.
- Enter the desired name (12 characters/spaces) using the pop-up keypad.

## Number of Stations

### To enter the number of stations...

- Touch the display box next to STATIONS.
- Use the pop-up keypad to enter the exact number of stations installed in the satellite. (Must be a multiple of eight between 8 and 64.)



If you attempt to enter a number that is not a multiple of eight, the number will be automatically adjusted to the next higher possibility. For example, if 41 was entered, TouchNet would automatically adjust the number to 48.

## Maximum Simultaneous Programs

Each program runs one satellite station at a time. The number entered here limits the number of programs (and therefore stations) the satellite can run at the same time to prevent exceeding its electrical output capacity. The range for this setting is 1-4.



When operating the TouchNet system via the Hand-Held Remote Interface option, up to six stations can be operated simultaneously.

## To set maximum simultaneous programs...

- Touch the display box next to MAX SIM PGMS.
- Make your entry (1-4) using the pop-up keypad.

## Flow Group Assignment

Assign the satellite to the Flow Group where most of its stations are located. This is a default setting only, and will expedite the Stations set up later. By default, satellites are assigned to Flow Group 1.

## To assign flow groups...

- Touch the display box next to FLOW GROUP to display the pop-up keypad.
- Enter the flow group number (1-20).



When assigning a satellite to a Flow Group, make sure the flow capacity of the Flow Group is equal to or greater than the flow requirements of any station controlled by the satellite. If it is not, the station will not operate, its run time will be set to "0", and a system alarm will be generated.

## To enable/disable communication ...

- Touch the box adjacent to the satellite number to toggle the communication link on and off. An "X" in the box indicates that the satellite communication is enabled. (The default for this setting is "disabled".)

## Programming the Controller (Golf) – 4



The Enable/Disable communications feature only applies to the satellite for uploading and downloading program data between the TouchNet and the satellite. When global commands are sent from the TouchNet, such as Manual Start (ALL), Cancel or Rain Hold, all satellites will respond regardless of the Enable/Disable selection.

You will need to repeat these steps for all satellites in your system. Use the << **SAT** and **SAT** >> scroll keys to access the remaining satellite address numbers.

When you have finished entering the satellite information, touch MENU to return to the Menu screen.

Once the satellite information is complete, the next step is to program the satellite station data.

### Satellite Station Setup

Select STATIONS from the system Menu screen. The Stations screen will appear, similar to the screen shown in **Figure 22**.

SAT #		PROGRAM			N-TIME	GPM	FLWGRP
1		HOLES 1 & 18					A-TIME
STA		PROGRAM		N-TIME	GPM	FLWGRP	
1		GREENS	F9	0:17	20	1	
2		GREENS	F9	0:17	20	1	
3		GREENS	F9	0:17	20	1	
4		GREENS	F9	0:17	20	1	

MENU RAIN << STA STA >> << SAT SAT >>

**Figure 22** - The Stations screen with GREENS F9 program assigned to four stations.

### The Stations screen allows you to...

- Assign a program to a station.
- Change the run time, flow rate and flow group assignment of each satellite station.

### To assign a program to a station...

- Select the satellite you wish to program by using the << **SAT** or **SAT** >> scroll keys to display the satellite address number, or by touching the SAT # box and entering the satellite address number using the pop-up keypad.

## Programming the Controller (Golf) – 4



An irrigation program and a switch program cannot be assigned to the same station. If you assign an irrigation program to a station previously assigned to a switch program, the station will be automatically removed from the switch program.

- Touch the PROGRAM box. The Select Program screen appears, as shown in **Figure 23**. (This screen lists all programs which have been defined via the Program Names screen.)

SELECT PROGRAM		FRI 06/21/96 01:06 PM	
FOR STATION(S) ON SAT 1			REMOVE_STA
GREENS	F9	FAIRWAYS	F9
GREENS	B9	FAIRWAYS	B9
TEES	F9	PROGRAM 7	
TEES	B9	PROGRAM 8	
SELECTED PROGRAM → GREENS			F9
OK		ESCAPE	

**Figure 23** - The Select Program screen.

- Touch the program you wish to assign to the station.
- Touch **OK** (or **ESCAPE** to exit the screen without selecting a program.)
- The Station screen is re-displayed and the PROGRAM box is now blinking.

### Time-saving tip...



While the function header (PROGRAM, N-TIME GPM [LPM] or FLWGRP) is blinking, the currently selected data of that function can be applied to any number of stations by continuing to touch the appropriate column of the desired station. Since only four stations of one satellite are displayed at a time, scroll to additional stations using the <<STA and STA>> keys as well as to other satellite numbers using the <<SAT and SAT>> keys.

- Touch the Program box of the desired station(s) to enter the program data.



If “(UNASSIGNED)” appears next to a station number, then no program has been assigned to the station. An unassigned station will not be started during the watering cycle.

# Programming the Controller (Golf) – 4

## To remove a station assignment...

- Touch the PROGRAM box to access the Select Program screen from the Station screen.
- Touch the REMOVE – STA box to activate that function.
- Touch **OK** to return to the Station screen.
- Touch the Program name of the selected station(s). The program will be removed and replaced with (UNASSIGNED).

## To change normal run times (N-TIME)...

- Touch the N-TIME box.
- Enter the time using the pop-up keypad. The maximum run time is 8 hours and 59 minutes (8:59). To set a run time in minutes only, enter “0” after the “Hours?” prompt.
- Touch the N-TIME box of the desired station(s) to enter the data.

## To set the Flow Rate and Flow Group assignment ...

- Use the same procedure as used to set the station run time.

Repeat the programming process for each station of each satellite in your system.

## A-TIME (Adjusted Run Time)

Touch the A-TIME box to display the Station Review screen. This screen displays the adjusted run times of the stations. These times are calculated from the percentages entered on the Adjust screen and cannot be changed from the Station Review screen.



The adjusted run times (A-time) will override the normal run times (N-time) defined on the Stations screen. For the A-time to equal the N-time, all percentage adjustments must be set to 100%.

When all satellite stations have been programmed, Master Watering Sequence schedules must be established by entering specific information on the Starts screen.

## Master Watering Sequences

A Master Watering Sequence includes a select group of programs which are ranked in order of operating priority. A start time and a watering day schedule are assigned to this program group. Up to 12 Master Watering Sequences can be established. Each sequence is ranked in order of operating priority according to its sequence number ranging from 1 to 12, with 1 being the highest priority.

The HydroGuard flow manager uses this information to calculate the watering schedule for each day.

The Master Watering Sequences are established on the Starts screen, like the example shown in **Figure 24**. To access this screen, select STARTS from the Menu screen.



# Programming the Controller (Golf) – 4

## The Starts Screen

Begin by selecting a Master Watering Sequence start number. Sequences are prioritized by their start number 1–12) entered in the START # display box. Start #1 is the highest priority.

STARTS		FRI 06/21/96 01:08 PM								
START #	1	AT	7:00 PM	SET DAYS						
<<STRT	STRT>>	PRI	SYRNG	S	M	T	W	T	F	S
GREENS	F9	1	0:00	CALENDAR						
TEES	F9	3	0:00							
GREENS	B9	2	0:00	TOTAL						
TEES	B9	4	0:00	TIME						
				3:10						
MENU		RAIN		<< PGM		PGM >>		SORT		CLEAR

Figure 24 - The watering sequence Starts screen. Start #1 set for 7:00 p.m.

### To assign a sequence start number...

- Touch <<STRT or STRT>> to scroll forward or backward through numbers 1–12 OR,
- Touch the box next to START # and use the pop-up keypad to enter the desired number.

After you have a sequence start number defined, you must set a specific start time for the sequence.

### To set the sequence start time...

- Touch the box displaying the start time (the default time is 12:00 a.m. [0:00]).
- Enter the desired start time using the pop-up keypad.



If you enter a start time which will occur **before** the Auto Download time, it places the Auto Download time within the Water Window. The Alarm condition “Auto Download Time is in the Water Window” will be generated. For more information on alarms, see “System Alarm 2,” page 77.



The start time assigned to the sequence initiates the watering operation, however, a sequence with a higher priority start number will interrupt a lower priority sequence start number during operation.

# Programming the Controller (Golf) – 4

## Set Watering Days

Next, set the active day schedule for each watering sequence by touching the Set Days box. The Set Water Days screen will appear as shown in **Figure 25**.

SET WATER DAYS		WED 03/06/96 01:08 PM			
MASTER SEQUENCE NO. 10					
7 DAY:	<input checked="" type="checkbox"/> SUN	<input checked="" type="checkbox"/> MON	<input checked="" type="checkbox"/> TUE	<input checked="" type="checkbox"/> WED	<input checked="" type="checkbox"/> THU
	<input checked="" type="checkbox"/> FRI	<input checked="" type="checkbox"/> SAT			
ALL DAYS.....:	<input type="checkbox"/> ON	<input type="checkbox"/> OFF			
INTERVAL [1-30 DAYS]:	INT 0	DAY 0			
CALENDAR ODD/EVEN..:	<input type="checkbox"/> ODD	<input type="checkbox"/> EVEN			
OK		ESCAPE			

Figure 25 - The Set Water Days screen.

Watering occurs only on watering days. The TouchNet provides four methods of selecting watering days. Each master sequence must use one of the following scheduling methods:

- 7-day calendar (weekly).
- All days on or all days off.
- Interval setting (1 to 30 days).
- Odd or Even calendar days.

Each of the scheduling methods is described below. Once you have selected the desired watering days, touch **OK** to return to the Starts screen. If you want to exit the Set Water Days screen without making any changes to your active days, touch **ESCAPE**.

### To select active days using the 7-DAY calendar...

- Touch the boxes of the desired days. An “X” will appear, indicating the day is selected. To remove a day, touch the box again and the “X” will disappear.

### To select or remove all days...

You can easily select or remove all days simultaneously by pressing the ALL DAYS ON or OFF box.

## Programming the Controller (Golf) – 4



To disable a master sequence start time or reset all days to inactive, select ALL DAYS OFF. With no active days assigned, the start time will be ignored.

### To set watering days by Interval...

The Interval method enables you to schedule watering days by how often watering is needed, such as every other day, every third day, etc. An interval schedule can be set from 1 (every day) to 30 (every thirty days). Once the interval frequency is selected, the first active watering day of the interval can be set so you will know exactly when the interval schedule will begin.

- Touch INT to select the interval frequency.
- Enter a number from 1 to 30 using the pop-up keypad.
- Touch DAY to define the first active day in the interval cycle, where 0 is today, 1 is tomorrow, etc.

For example, if INT = 5 and DAY = 1, your irrigation programs would be active every fifth day, starting tomorrow.



In order for an Interval schedule to be active and other day scheduling methods to be deselected, a value other than 0 must be entered in the INT box.

The default value for both INT and DAY is 0. If DAY = 0, the first active day in the interval will be today, assuming you make this selection prior to downloading information to the satellites and before the start of your watering for the day.

### To set active days using the ODD/EVEN calendar...

- Touch ODD or EVEN to base active days on actual calendar days where the 2nd, 4th, 28th, etc. are even days and the 1st, 3rd, 5th, etc. are odd days.



When using the ODD/EVEN calendar, remember that two odd days can fall consecutively at the end of one month and the beginning of the next (the 31st and the 1st). If you have selected ODD, your system will water two days in a row which may cause over-watering. If you have chosen EVEN active days, your system will not water for two days; this may result in under-watering. To compensate on the days this occurs, you may use the Adjust screen and apply a percentage adjustment to increase or decrease your watering time.

### Set Program Priority

Next, programs will be assigned to the watering sequence and prioritized for order of operation.

Generally, higher priority programs, such as PRI 1 or PRI 2, will run before lower priority programs, such as PRI 7 or PRI 8. A program with a priority of “0” will not be included in the sequence run time or the flow management process.

# Programming the Controller (Golf) – 4

## To set program priorities...

- Touch the display box under the PRI column, next to the program name. The pop-up keypad is displayed.
- Enter a priority number to each program (1 to 8). You cannot use the same priority number twice. Leave the priority set to 0 if you do not want the program to be included with this start sequence.
- Use the << **PGM** and **PGM** >> keys to scroll through the program list.

## Sort Function Key

Once you have set the priority for all desired programs, you can press the SORT function key at the bottom of the Starts screen to automatically organize the programs into priority sequence. **Figure 26** shows the display after the Sort function has been applied.

STARTS		FRI 06/21/96 01:08 PM								
START #		1	AT 7:00 PM	SET DAYS						
<<STRT	STRT>>	PRI	SYRNG	S	M	T	W	T	F	S
GREENS	F9	1	0:00	CALENDAR						
GREENS	B9	2	0:00							
TEES	F9	3	0:00	TOTAL						
TEES	B9	4	0:00	TIME						
				3:10						
MENU		RAIN		<< PGM PGM >>		SORT		CLEAR		

Figure 26 - The Starts screen after sorting the programs by priority.

## Clear Function Key

To reprogram the sequence start, you can reset all programs to "0" priority by pressing the CLEAR function key at the bottom of the screen.

## Set Syringe/Test Cycle Time

Within the Starts screen, you can set a program to run a syringe/test cycle instead of its adjusted station run times.

## To set syringe/test cycle time...

- Select the desired program in the SYRNG (Syringe) column.
- Use the pop-up keypad to set the amount of syringe/test cycle time (1-30 minutes).

## Programming the Controller (Golf) – 4

Repeat these programming steps for each required watering sequence start (12 maximum).

### **Total Run Time Calculation**

The TOTAL TIME display indicates the calculated run time for the entire watering sequence. This information will appear after the TouchNet performs the flow management calculations at the Update Time (specified on the Setup screen) and/or after CALCULATE is selected on the Water Window screen.



Before you begin irrigating, you need to access the Water Window screen and define the end time limit. To access this screen, touch WATER WINDOW on the Menu screen.

To enable the TouchNet to operate manually or automatically, the flow management calculations must first be performed. To accomplish this, refer to Calculated End Time on page 73.

This completes the TouchNet programming procedure for irrigation. To establish Switch programs, see page 60. To test the system operation, continue to “Manual Operation” on page 64.

## Commercial Site Layout Example

Figure 27

System Flow = 150 GPM  
Flow Group #4 = 80 GPM

Satellite #1  
"Soccer"  

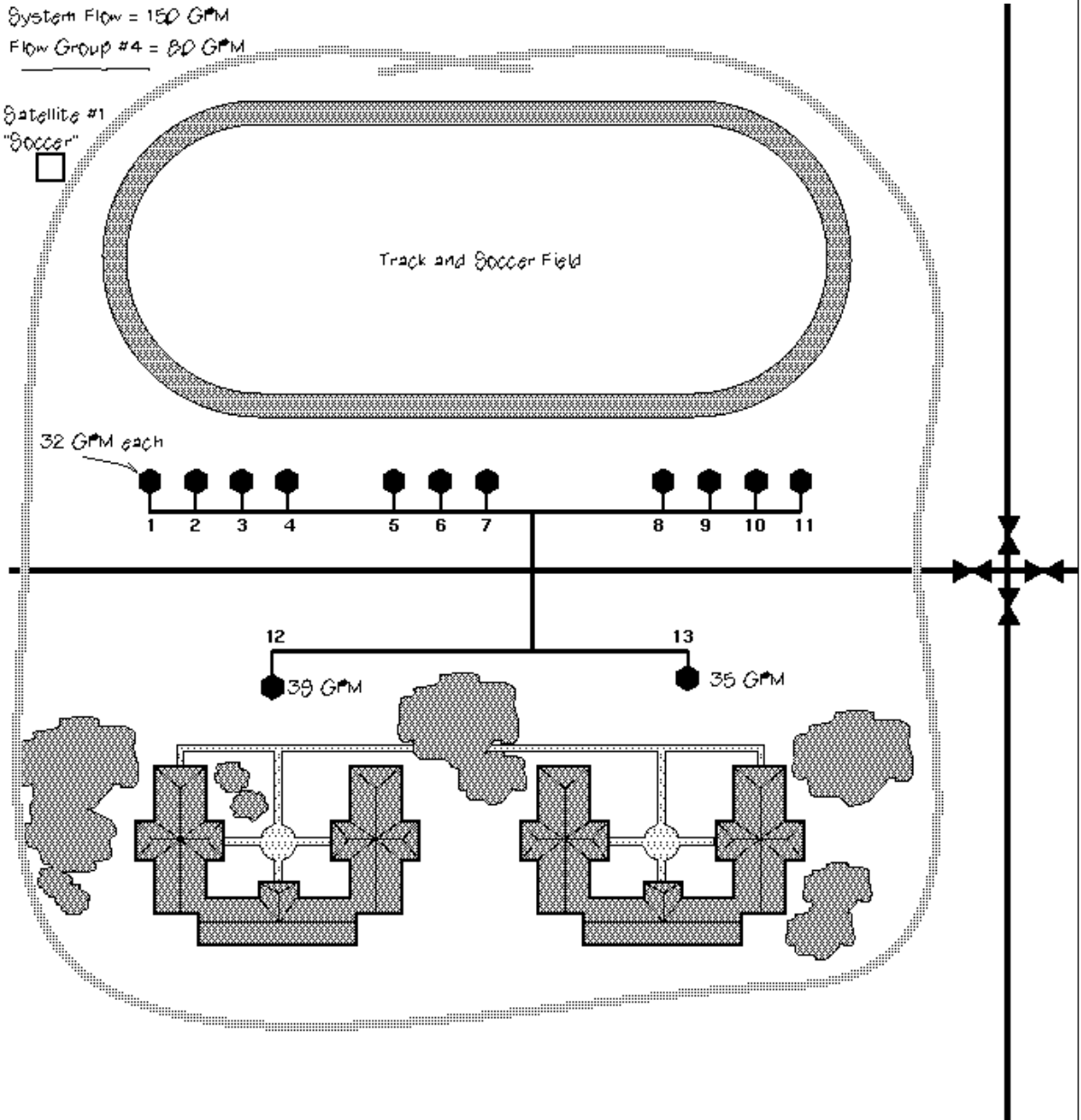

# Programming the Controller (Commercial) – 4

Figure 29

## Network LTC™ Satellite Field Data Worksheet

<b>Satellite No.</b>	1
<b>Name/Area</b>	Soccer
<b>Max Sim Pgms</b>	1
<b>Flow Group</b>	4

Switch Program #	Start Times			
	Start 1	Start 2	Start 3	Start 4
Switch 1	5:00 a.m.			

Sta.	Program	Time	Flow	Group
1	soccer	15	32	4
2	soccer	15	32	4
3	soccer	15	32	4
4	soccer	15	32	4
5	soccer	15	32	4
6	soccer	15	32	4
7	soccer	15	32	4
8	soccer	15	32	4
9	soccer	15	32	4
10	soccer	15	32	4
11	soccer	15	32	4
12	turf	30	39	4
13	turf	30	35	4
14				
15				
16				
17				
18				
19				
20				
21				
22				
23				
24	switch 1	12 hrs		
25				
26				
27				
28				
29				
30				
31				
32				

Sta.	Program	Time	Flow	Group
33				
34				
35				
36				
37				
38				
39				
40				
41				
42				
43				
44				
45				
46				
47				
48				
49				
50				
51				
52				
53				
54				
55				
56				
57				
58				
59				
60				
61				
62				
63				
64				



# Programming the Controller (Commercial) – 4

## System Hydraulics Setup

To begin, you will need to define your irrigation system hydraulic capacities (limits). The Hydraulics screen allows you to specify maximum flow for the system and the maximum flow for each flow group.



Entering accurate information on the Hydraulics screen is essential for proper operation of the HydroGuard flow management system.

The HydroGuard flow manager ensures that system flow capacity is utilized at peak efficiency throughout the watering cycle. This results in the maximum amount of water being supplied in the minimum amount of time, while protecting the system and defined Flow Groups from excessive flow conditions.

HYDRAULICS		TUE 02/25/97 01:03 PM	
SYSTEM FLOW	<input type="text" value="150"/>	GPM	
FLOW GROUP 1	<input type="text" value="50"/>	GPM	
FLOW GROUP 2	<input type="text" value="80"/>	GPM	
FLOW GROUP 3	<input type="text" value="50"/>	GPM	
FLOW GROUP 4	<input type="text" value="80"/>	GPM	
MENU RAIN CANCEL MANUAL <<FGRP FGRP>>			

Figure 30 - The Hydraulics Screen showing System and Group flow values.

### Setting up the hydraulic values...

- Select the HYDRAULICS box from the system Menu screen. The Hydraulics screen will appear as shown in **Figure 30**.
- Touch the box adjacent to SYSTEM FLOW.
- Use the pop-up keypad to enter the flow capacity of your irrigation system (3,000 GPM [12,000 LPM] maximum).
- Enter the flow limit for each Flow Group (1–20) in the same manner.

Only four Flow Groups can be displayed at one time on the Hydraulics screen. To scroll forward through the group list, touch the **FGRP>>** key. To scroll backward, touch the **<<FGRP** key.

# Programming the Controller (Commercial) – 4

When you are finished entering the flow rate data, return to the Menu screen by touching the MENU key.

## Watering Program Setup

The next step is to define the operating information for each watering program.

Select PROGRAMS from the system Menu screen. The Programs screen will appear as shown in **Figure 31**.

		NAME	TIME	GPM
PGM	1	PROGRAM 1	0:00	0
PGM	2	PROGRAM 2	0:00	0
PGM	3	PROGRAM 3	0:00	0
PGM	4	PROGRAM 4	0:00	0
		REPEATS /	SOAK TIME	

MENU RAIN CANCEL MANUAL << PGM PGM >>

Figure 31 - The Programs screen.

### The Programs screen enables you to...

- Change the name of each program
- Define a general run time and flow rate for each program
- Define a soak time and the number of repeat cycles for each program



The run time and flow rate information entered on the Programs screen can be transferred to the Stations screen to expedite station programming. It is important to remember that the Programs screen data is not dynamically linked to the satellite Stations screen. In other words, the information entered on the Programs screen will not automatically enter or update the information on the Stations screen. The run times and flow rates entered on the Programs screen will provide a general starting point for station programming and can be fine-tuned on the Stations screen.

### Naming Programs

By default, the programs are named Program 1, Program 2, etc. If you choose to rename a program, you may select one of 14 names already provided in the TouchNet memory, or you may

## Programming the Controller (Commercial) – 4

rename the programs as you wish utilizing up to 12 characters and spaces for each name.

### To rename a program...

- On the Programs screen, touch the Name box of the program you wish to rename. The Program Names screen appears, as shown in **Figure 32**.

PROGRAM NAMES		THU 03/06/97 01:00 PM	
TURF	SHRUBS	ANNUALS	
TREES	DRIP	MEDIAN STRIP	
SPRAYS	ROTORS	ROTORS	2
SLOPE	SUNNY	SHADY	
FRONT	BACK	OTHER	
SELECTD PGM ->TURF		SPELL IT OUT	
OK		ESCAPE	

Figure 32 - Program Names screen.

- Touch a listed name to select it. The name will be displayed next to “SELECTD PGM” (selected program).
- Touch the **OK** key to complete the selection, or touch the **ESCAPE** key to exit the Program Names screen without any changes being made.
- To type in a name, Touch the SPELL IT OUT box.
- Enter the name (up to 12 characters/spaces) using the pop-up keypads.



To type a space in the name, use the <SP> key provided on the third keypad.

- Touch the Enter key. The Program Names screen will appear and the new program name will be displayed next to “SELECTD PGM”.
- Touch the **OK** key to complete the selection, or touch the **ESCAPE** key to exit the Program Names screen without any changes being made.
- The Programs screen will appear with the program name you selected.
- Repeat the process as needed for each program.
- Use the **PGM>>** or **<<PGM** keys to access additional programs.

# Programming the Controller (Commercial) – 4

## Setting Program Run Time and Flow

In addition to assigning a program name, you can define the default station run times and station flow rates for each program. As mentioned previously, this data can be transferred to the Satellite Stations screen as default information to expedite the programming process. Therefore, you should enter the run time and flow rate which will be used for the majority of stations the program will be assigned to.

### To set program run times...

- Touch the TIME display box for the desired program.
- Follow the prompts on the pop-up keypad to enter the run time. (8 hours, 59 minutes maximum.)

### To set program flow rates...

- Touch the GPM (LPM) display box for the desired program.
- Follow the prompts on the pop-up keypad to enter the flow rate. (3,000 GPM or 12,000 LPM maximum.)



The program flow rate must not exceed the System and/or Group flow limits. A system alarm will be generated if this occurs.

PROGRAMS		TUE 02/27/96 01:04 PM	
	NAME	TIME	GPM
PGM 1	TURF	0:30	35
PGM 2	SOCCER	0:30	32
PGM 3	SPRAYS	0:20	35
PGM 4	SLOPE	0:15	39
REPEATS / SOAK TIME			
MENU RAIN CANCEL MANUAL << PGM/PGM >>			

Figure 33 - The Programs screen with program names, run times and flow values defined.

## Programming the Controller (Commercial) – 4

### To set Repeats/Soak times...

- Touch the REPEATS/SOAK TIME box on the bottom of the Programs screen. The Repeats/Soak-Time screen appears as shown in **Figure 34**.
- Touch the SOAK TIME display box for the desired program.
- Enter the number of minutes (0–59 minutes) using the pop-up keypad.

REPEATS/SOAK-TIME TUE 02/27/96 01:04 PM

	NAME	SOAK TIME	REPEATS
PGM 1	TURF	0:00	0
PGM 2	SOCCER	0:00	0
PGM 3	SPRAYS	0:00	0
PGM 4	SLOPE	0:30	1
RUN TIME/FLOW VOL.			

MENU RAIN CANCEL MANUAL << PGM/PGM >>

**Figure 34** - The Repeats/Soak-Time screen with program soak time and repeats defined.

- Touch the REPEATS display box for the desired program.
- Enter the number of repeats (0–3) using the pop-up keypad.

When finished, you can touch the RUN TIME/FLOW VOL box to toggle back to the Programs screen, or you can touch MENU to return to the Menu screen.

Having defined the programs, the next step is to enter specific operating information for each satellite.

# Programming the Controller (Commercial) – 4

## Satellite Setup

Select SATELLITES from the system Menu screen. The Satellites screen will appear similar to **Figure 35**.

SATELLITES		FRI 06/20/97 01:05 PM	
SATELLITE #		1..... X	
WIRE	RADIO	TELEPH	
NAME/AREA	SOCCER		
STATIONS	16		
MAX SIM PGMS	1		
FLOW GROUP	4		
MENU		RAIN CANCEL << SAT SAT >> STAS	

**Figure 35** - Satellites screen defined for example satellite #1.

The TouchNet has the capability of communicating with 35 unique satellite addresses which consist of a two-digit number from 1 to 35. Each satellite in the system must be assigned to one of the address numbers to enable communication with the TouchNet. The satellite specifications required by the TouchNet are entered on the Satellites screen.

### For each satellite, the Satellites screen allows you to...

- Define the method of central/satellite communication
- Customize the satellite name
- Define the number of stations installed
- Define the maximum number of programs that can run simultaneously when controlled by the TouchNet
- Define the Flow Group assignment
- Enable and disable communication to/from the TouchNet



The first time the Satellite screen is displayed, it will show Satellite # 1 information. To select a different satellite, touch the <<SAT or SAT>> keys.

### Communication Method

Wireline is the default method of communication. Radio and telephone communications require optional hardware installation to be utilized. Refer to the instructions provided with the optional Radio Link and Telephone kits for detailed information.

### Name/Area

The Name/Area option allows you to rename the satellite as you choose. The satellites are pre-named Satellite 1, Satellite 2, etc.

# Programming the Controller (Commercial) – 4

## To enter a name...

- Touch the display box next to NAME/AREA.
- Enter the desired name (12 characters/spaces) using the pop-up keypad.

## Number of Stations

### To enter the number of stations...

- Touch the display box next to STATIONS.
- Use the pop-up keypad to enter the exact number of stations installed in the satellite. (Must be a multiple of eight between 8 and 64.)



If you attempt to enter a number that is not a multiple of eight, the number will be automatically adjusted to the next higher possibility. For example, if 41 was entered, TouchNet would automatically adjust the number to 48.

## Maximum Simultaneous Programs

Each program runs one satellite station at a time. The number entered here limits the number of programs (and therefore stations) the satellite can run at the same time to prevent exceeding its electrical output capacity. The range for this setting is 1-4.

When operating the TouchNet system via the Hand-Held Remote Interface option, up to six stations can be operated simultaneously.

### To set maximum simultaneous programs...

- Touch the display box next to MAX SIM PGMS.
- Make your entry (1-4) using the pop-up keypad.

## Flow Group Assignment

Assign the satellite to the Flow Group where most of its stations are located. This is a default setting only, and will expedite the Stations set up later. By default, satellites are assigned to Flow Group 1.

### To assign flow groups...

- Touch the display box next to FLOW GROUP to display the pop-up keypad.
- Enter the flow group number (1-20).



When assigning a satellite to a Flow Group, make sure the flow capacity of the Flow Group is equal to or greater than the flow requirements of any station controlled by the satellite. If it is not, the station will not operate, its run time will be set to "0", and a system alarm will be generated.

### To enable/disable communication ...

- Touch the box adjacent to the satellite number to toggle the communication link on and off. An "X" in the box indicates that the satellite communication is enabled. (The default for this setting is "disabled".)

# Programming the Controller (Commercial) – 4



The Enable/Disable communications feature only applies to the satellite for uploading and downloading program data between the TouchNet and the satellite. When global commands are sent from the TouchNet, such as Manual Start (ALL), Cancel or Rain Hold, all satellites will respond regardless of the Enable/Disable selection.



For telephone communication satellites, upon power up, TouchNet will automatically dial up all satellites with a declared non-zero phone number regardless of the Enable/Disable selection.

You will need to repeat these steps for all satellites in your system. Use the << **SAT** and **SAT** >> scroll keys to access the remaining satellite address numbers.

When you have finished entering the satellite information, touch MENU to return to the Menu screen.

Once the satellite information is complete, the next step is to program the satellite station data.

### Satellite Station Setup

Select STATIONS from the system Menu screen. The Stations screen will appear, similar to the screen shown in **Figure 36**.

SAT #		1	SOCCER		A-TIME
		PROGRAM	N-TIME	GPM	FLWGRP
STA	1	SOCCER	0:30	32	4
STA	2	SOCCER	0:30	32	4
STA	3	SOCCER	0:30	32	4
STA	4	SOCCER	0:30	32	4

MENU RAIN << STA STA >> << SAT SAT >>

**Figure 36** - The Stations screen with Soccer program assigned to four stations.

### The Stations screen allows you to...

- Assign a program to a station.
- Change the run time, flow rate and flow group assignment of each satellite station.

### To assign a program to a station...

- Select the satellite you wish to program by using the << **SAT** or **SAT** >> scroll keys to display the satellite address number, or by touching the SAT # box and entering the satellite address number using the pop-up keypad.



## Programming the Controller (Commercial) – 4



An irrigation program and a switch program cannot be assigned to the same station. If you assign an irrigation program to a station previously assigned to a switch program, the station will be automatically removed from the switch program (and vice versa).

- Touch the PROGRAM box. The Select Program screen appears, as shown in **Figure 37**. (This screen lists all programs which have been defined in the Program Names screen.)

SELECT PROGRAM		FRI 06/20/97 01:06 PM	
FOR STATION(S) ON SAT		1	REMOVE_STA
TURF	PROGRAM	5	
SOCCER	PROGRAM	6	
SPRAYS	PROGRAM	7	
SLOPE	PROGRAM	8	
SELECTED PROGRAM -> TURF			
OK		ESCAPE	

**Figure 37** - The Select Program screen.

- Touch the program you wish to assign to the station.
- Touch **OK** to enter the information or **ESCAPE** to exit the screen without selecting a program.)
- The Station screen is re-displayed and the PROGRAM box is now blinking.



### Time-saving tip...

While the function header (PROGRAM, N-TIME GPM [LPM] or FLWGRP) is blinking, the currently selected data of that function can be applied to any number of stations by continuing to touch the appropriate column of the desired station. Since only four stations of one satellite are displayed at a time, scroll to additional stations using the <<**STA** and **STA**>> keys as well as to other satellite numbers using the <<**SAT** and **SAT**>> keys.

- Touch the Program box of the desired station(s) to enter the program data.



If “(UNASSIGNED)” appears next to a station number, then no program has been assigned to the station. An unassigned station will not be started during the watering cycle.

# Programming the Controller (Commercial) – 4

## To remove a station assignment...

- Touch the PROGRAM box to access the Select Program screen from the Station screen.
- Touch the REMOVE – STA box to activate that function.
- Touch **OK** to return to the Station screen.
- Touch the Program name of the selected station(s). The program will be removed and replaced with (UNASSIGNED).

## To change normal run times (N-TIME)...

- Touch the N-TIME box.
- Enter the time using the pop-up keypad. The maximum run time is 8 hours and 59 minutes (8:59). To set a run time in minutes only, enter “0” after the “Hours?” prompt.
- Touch the N-TIME box of the desired station(s) to enter the data.

## To set the Flow Rate and Flow Group assignment ...

- Use the same procedure as used to set the station run time.

Repeat the programming process for each station of each satellite in your system.

## A-TIME (Adjusted Run Time)

Touch the A-TIME box to display the Station Review screen. This screen displays the adjusted run times of the stations. These times are calculated from the percentages entered on the Adjust screen and cannot be changed from the Station Review screen.



The adjusted run times (A-time) will override the normal run times (N-time) defined on the Stations screen. For the A-time to equal the N-time, all percentage adjustments must be set to 100%.

When all satellite stations have been programmed, Master Watering Sequence schedules must be established by entering specific information on the Starts screen.

## Master Watering Sequences

A Master Watering Sequence includes a select group of programs which are ranked in order of operating priority. A start time and a watering day schedule are assigned to this program group. Up to 12 Master Watering Sequences can be established. Each sequence is ranked in order of operating priority according to its sequence number ranging from 1 to 12, with 1 being the highest priority.

The HydroGuard flow manager uses this information to calculate the watering schedule for each day.

The Master Watering Sequences are established on the Starts screen, like the example shown in **Figure 38**. To access this screen, select STARTS from the Menu screen.

# Programming the Controller (Commercial) – 4

## The Starts Screen

Begin by selecting a Master Watering Sequence start number. Sequences are prioritized by their start number entered in the START # display box.

STARTS		FRI 06/20/97 01:08 PM	
START #	1	AT 1:00 AM	SET DAYS
<<STRT STRT>>	PRI	SYRNG	S M T W T F S
SOCCER	1	0:00	CALENDAR
SLOPE	4	0:00	
TURF	2	0:00	TOTAL TIME
SPRAYS	3	0:00	3:10
MENU RAIN << PGM PGM >> SORT CLEAR			

Figure 38 - The watering sequence Starts screen. Start #1 set for 1:00 a.m.

### To assign a sequence start number...

- Touch <<STRT or STRT>> to scroll forward or backward through numbers 1-12 OR,
- Touch the box next to START # and use the pop-up keypad to enter the desired number.

After you have a sequence start number defined, you must set a specific start time for the sequence.

### To set the sequence start time...

- Touch the box displaying the start time (the default time is 12:00 a.m. [0:00]).
- Enter the desired start time using the pop-up keypad.



If you enter a start time which will occur **before** the Auto Download time, it places the Auto Download time within the Water Window. The Alarm condition "Auto Download Time is in the Water Window" will be generated. For more information on alarms, see "System Alarm 2," page 76.



The start time assigned to the sequence initiates the watering operation, however, a sequence with a higher priority start number will interrupt a lower priority sequence start number during operation.

# Programming the Controller (Commercial) – 4

## Set Watering Days

Next, set the active day schedule for each watering sequence by touching the Set Days box. The Set Water Days screen will appear as shown in **Figure 39**.

SET WATER DAYS		WED 03/06/96 01:08 PM			
MASTER SEQUENCE NO. 10					
7 DAY:	<input checked="" type="checkbox"/> SUN	<input checked="" type="checkbox"/> MON	<input checked="" type="checkbox"/> TUE	<input checked="" type="checkbox"/> WED	<input checked="" type="checkbox"/> THU
	<input checked="" type="checkbox"/> FRI	<input checked="" type="checkbox"/> SAT			
ALL DAYS.....:	ON	OFF			
INTERVAL [1-30 DAYS]:	INT 0	DAY 0			
CALENDAR ODD/EVEN..:	<input type="checkbox"/> ODD	<input type="checkbox"/> EVEN			
OK		ESCAPE			

Figure 39 - The Set Water Days screen.

Watering occurs only on watering days. The TouchNet provides four methods of selecting watering days. Each master sequence must use one of the following scheduling methods.

- 7-day calendar (weekly).
- All days on or all days off.
- Interval setting (1 to 30 days).
- Odd or Even calendar days.

Each of the scheduling methods is described below. Once you have selected the desired watering days, touch **OK** to return to the Starts screen. If you want to exit the Set Water Days screen without making any changes to your active days, touch **ESCAPE**.

### To select active days using the 7-DAY calendar...

- Touch the boxes of the desired days. An “X” will appear, indicating the day is selected. To remove a day, touch the box again and the “X” will disappear.

### To select or remove all days...

You can easily select or remove all days simultaneously by pressing the ALL DAYS ON or OFF box.

## Programming the Controller (Commercial) – 4



To disable a master sequence start time or reset all days to inactive, select ALL DAYS OFF. With no active days assigned, the start time will be ignored.

### To set watering days by Interval...

The Interval method enables you to schedule watering days by how often watering is needed, such as every other day, every third day, etc. An interval schedule can be set from 1 (every day) to 30 (every thirty days). Once the interval frequency is selected, the first active watering day of the interval can be set so you will know exactly when the interval schedule will begin.

- Touch INT to select the interval frequency.
- Enter a number from 1 to 30 using the pop-up keypad.
- Touch DAY to define the first active day in the interval cycle, where 0 is today, 1 is tomorrow, etc.

For example, if INT = 5 and DAY = 1, your irrigation programs would be active every fifth day, starting tomorrow.



In order for an Interval schedule to be active and other day scheduling methods to be deselected, a value other than 0 must be entered in the INT box.

The default value for both INT and DAY is 0. If DAY = 0, the first active day in the interval will be today, assuming you make this selection prior to downloading information to the satellites and before the start of your watering for the day.

### To set active days using the ODD/EVEN calendar...

- Touch ODD or EVEN to base active days on actual calendar days where the 2nd, 4th, 28th, etc. are even days and the 1st, 3rd, 5th, etc. are odd days.



When using the ODD/EVEN calendar, remember that two odd days can fall consecutively at the end of one month and the beginning of the next (the 31st and the 1st). If you have selected ODD, your system will water two days in a row which may cause over-watering. If you have chosen EVEN active days, your system will not water for two days; this may result in under-watering. To compensate on the days this occurs, you may use the Adjust screen and apply a percentage adjustment to increase or decrease your watering time.

### Set Program Priority

Next, programs will be assigned to the watering sequence and prioritized for order of operation.

Generally, higher priority programs, such as PRI 1 or PRI 2, will run before lower priority programs, such as PRI 7 or PRI 8. A program with a priority of "0" will not be included in the sequence run time or the flow management process.

# Programming the Controller (Commercial) – 4

## To set program priorities...

- Touch the display box under the PRI column, next to the program name. The pop-up keypad is displayed.
- Enter a priority number to each program (1 to 8). You cannot use the same priority number twice. Leave the priority set to 0 if you do not want the program to be included with this start sequence.
- Use the << **PGM** and **PGM** >> keys to scroll through the program list.

## Sort Function Key

Once you have set the priority for all desired programs, you can press the **SORT** function key at the bottom of the Starts screen to automatically organize the programs into priority sequence. **Figure 40** shows the display after the Sort function has been applied.

STARTS		FRI 06/20/97 01:08 PM	
START #	1	AT 1:00 AM	SET DAYS
<<STRT STRT>>	FRI	SYRNG	SMTWTFSS
SOCCER	1	0:00	CALENDAR  TOTAL TIME 3:10
TURF SLOPE	2	0:00	
SPRAYS	3	0:00	
SLOPE	4	0:00	
MENU		RAIN	<< PGM PGM >> SORT CLEAR

Figure 40 - The Starts screen after sorting the programs by priority.

## Clear Function Key

To reprogram the sequence start, you can reset all programs to "0" priority by pressing the CLEAR function key at the bottom of the screen.

## Set Syringe/Test Cycle Time

Within the Starts screen, you can set a program to run a syringe/test cycle instead of its adjusted station run times.

## To set syringe/test cycle time...

- Select the desired program in the SYRNG (Syringe) column.
- Use the pop-up keypad to set the amount of syringe/test cycle time (1-30 minutes).

## Programming the Controller (Commercial) – 4

Repeat these programming steps for each required watering sequence start (12 maximum).

### **Total Run Time Calculation**

The TOTAL TIME display indicates the calculated run time for the entire watering sequence. This information will appear after the TouchNet performs the flow management calculations at the Update Time (specified on the Setup screen) and/or after CALCULATE is selected on the Water Window screen.



Before you begin irrigating, you need to access the Water Window screen and define the end time limit. To access this screen, touch WATER WINDOW on the Menu screen.

To enable the TouchNet to operate manually or automatically, the flow management calculations must first be performed. To accomplish this, refer to Calculated End Time on page 73.

This completes the TouchNet programming procedure for irrigation. To establish switch programs, see page 60. To test the system operation, continue to “Manual Operation” on page 64.

# Switch Programs

## About Switch Programs

The TouchNet provides eight independent programs dedicated to the operation of switch-controlled devices such as security lighting, decorative fountains, etc.

Due to the general use of switch-controlled devices, the program scheduling parameters are somewhat different than those provided for irrigation programs. The daily activity schedule is similar to irrigation programs, in that active days can be selected by 7-day Calendar or 1-30-day Interval. However, unlike irrigation programs which have 12 start times available per day, switch programs have four definable start times per day and can operated for extended periods up to 23 hours and 59 minutes. Since flow management is not required for switch operation, the switch programs are not included in the flow calculations, affected by percent adjust factors or constrained by hydraulic capacity or watering window limits.



Switch program information is downloaded to the satellites in conjunction with the irrigation programs during an automatic or manual download. Switch program changes will not be recognized by the satellites until a download has been completed. Switch programs in operation will not be canceled by a download process.

Select the SWITCH PROGRAMS screen by touching SWITCH PRGMS from the system MENU screen. See **Figure 41**.

SWITCH PROGRAMS		TUE 02/25/97 01:04 PM		
[1 - 4]				
NAMES	SAT. #	PROG #	STA #	TIME
SWITCH 1				0:00
SWITCH 2				0:00
SWITCH 3				0:00
SWITCH 4				0:00
SWITCH MODE->	MANUAL		SCHEDULED	
MENU	<<SWCH SWCH>>			

Figure 41 - The Switch Programs screen.



## Switch Programs – 5

### From the Switch Programs screen you can...

- Select the satellite and station to assign a switch program.
- Enter a specific run time for each switch program.
- Customize the switch program names.
- Select the scheduling screen to set active day and start time schedules.
- Select the Manual Switch screen for manual operation.

### Switch Program Setup

- Switch programs 1–4 will be displayed first. To select switch program 5–8 press the <<SWCH or SWCH>> key.

### To rename a switch program...

- Touch the desired switch number box to display the SWITCH PROGRAM NAMES screen as shown in **Figure 42**.
- Touch a predefined name to select it. The name will be displayed next to “SELECTD PGM →”.

SWITCH PRGRM NAMES THU 03/06/97 01:00 PM		
SWITCH 1	SWITCH 2	SWITCH 3
SWITCH 4	SWITCH 5	SWITCH 6
SWITCH 7	SWITCH 8	
		OTHER
SELECTD PGM → SWITCH 1		SPELL IT OUT
	OK	ESCAPE

**Figure 42** - The Switch Program Names screen.

- To customize the program name, touch the SPELL IT OUT box.
- Enter the name (up to 12 characters/spaces) using the pop-up keypads.



To type a space in the name, use the <SP> key provided on the third keypad.

- Touch the **Enter**  key. The new program name will be displayed next to “SELECTD PGM →”.
- Touch the **OK** key to complete the selection, or touch the **ESCAPE** key to exit without any changes being made.
- Repeat the procedure for each switch program name you wish to change.

## About switch program assignment...



A Switch program and an irrigation program cannot be assigned to the same satellite station. If a switch program is assigned to a station previously assigned to an irrigation program, the station will be automatically removed from the irrigation program.

- A Switch program can be assigned to only one satellite.
- A satellite is limited to two Switch program assignments.
- Switch programs are assigned as program 9 and 10. This number is automatically entered as 9 for the first switch program assigned to the satellite and 10 for the second. Attempting to assign a third switch program to a satellite will result in disabling the most recently assigned switch program.
- The Network LTC Plus satellite will display programs 17 and/or 18 when running Switch programs. These programs are not accessible through the satellite timing mechanism.

## To assign the satellite number, station number and run time...

- Touch the SAT # box adjacent to the desired switch program. Use the pop-up keypads to enter the desired satellite number.



The TouchNet automatically checks the previously defined satellite information to determine the available station count. Any station number entry larger than the actual station count will be ignored.

- Enter the desired satellite station number (STA #) and run time (TIME) (1 minute to 23 hours and 59 minutes) in the same manner.

SWITCH PROGRAMS					TUE 02/25/97 01:04 PM	
[1 - 4]						
NAMES		SAT. #	PROG #	STA #	TIME	
SWITCH	1	1	9	24	12:00	
SWITCH	2				0:00	
SWITCH	3				0:00	
SWITCH	4				0:00	
SWITCH MODE->		MANUAL		SCHEDULED		
MENU		<<SWCH SWCH>>				

Figure 43 - The Switch Programs screen with data entered for satellite #1.

## Switch Programs – 5



Deleting a Station # also deletes the Program # but does not affect the run time setting. Deleting the Satellite # deletes the Station #, Program # and resets the run time to zero.

### To assign active days and start times...

- Touch the SCHEDULED box at the bottom of the screen. The SWITCH SCHEDULE screen will appear as shown in **Figure 44**.

SWITCH SCHEDULE		WED 03/05/97 01:08 PM	
SWITCH PROGRAM No. 1		<<SWCH SWCH>>	
7 DAY:	<input checked="" type="checkbox"/> SUN	<input checked="" type="checkbox"/> MON	<input checked="" type="checkbox"/> TUE
	<input checked="" type="checkbox"/> WED	<input checked="" type="checkbox"/> THU	
	<input checked="" type="checkbox"/> FRI	<input checked="" type="checkbox"/> SAT	
INTERVAL [1-30 DAYS]:	INT 0	DAY 0	
5:00 AM	1	START	3
	2	No.	4
OK ESCAPE CLEAR1 CLEAR2 CLEAR3 CLEAR4			

**Figure 44** - The Switch Schedule screen with data entered for satellite #1.

- Select the Switch program number (if necessary) using the <<SWCH or SWCH>> keys.
- Select a 7-day schedule by touching the appropriate day abbreviation boxes. An X in the box indicates the day is selected. Or, set an Interval schedule by touching the INT and DAY boxes and using the pop-up keypads to enter the desired interval and start day numbers.



Refer to page 57 for detailed information on setting a day schedule by Interval.

- Touch the Start No. 1 box and enter the desired start time using the pop-up keypad. Repeat for each additional each start time (2-4).



To quickly delete a Switch program start time, touch the appropriate CLEAR key (CLEAR 1 -CLEAR 4).

- Touch the **OK** key to complete the selection, or touch the **ESCAPE** key to exit the Switch Schedule screen without any changes being made.
- Repeat this procedure to set an operating schedule for each switch program.



For manual operation of the Switch programs, refer to Manual Operation, page 64.

# Manual Operation

## About Manual Operation

The TouchNet provides separate manual operations screens for irrigation programs and switch programs. The Manual irrigation screen, shown in **Figure 45**, will appear when MANUAL is selected from the MENU screen.

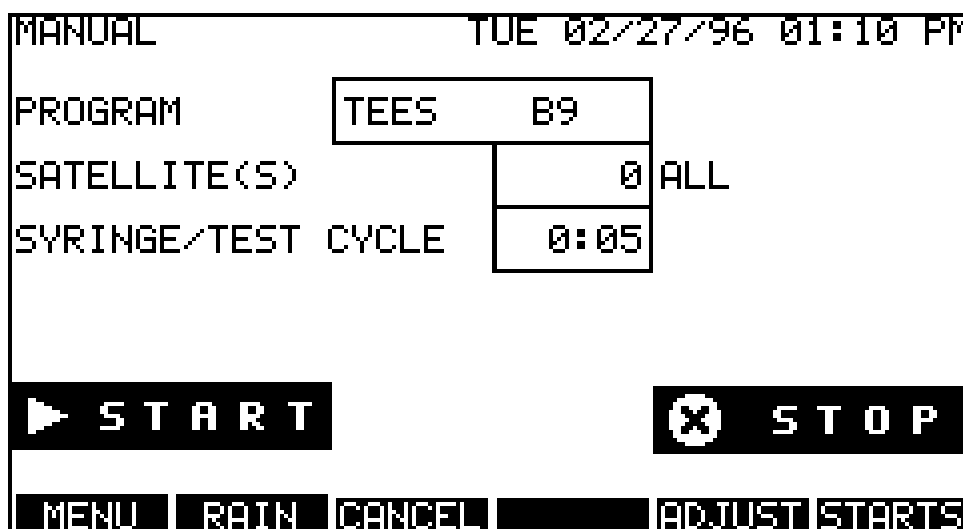

Figure 45 - The Manual screen for irrigation programs.

### From the Manual (irrigation) screen you can...

- Manually start and stop a specific program for a specific satellite or all satellites.
- Override the specified run time of the program with a Syringe/Test run time from 1 to 30 minutes.



A manual start may pause an automatic watering operation currently running. Upon completion of the manual operation, the paused automatic operation will resume.

### To run a watering program manually...

- Select the program by touching the Program Name box. The Select Program screen will appear.
- Touch the program you wish to operate and press OK.
- Select a specific satellite by touching the Satellite number box and entering its address number using the pop-up keypad. To select ALL satellites, enter "0".

- If you want to temporarily change the program run time using the the Syringe/Test option, touch the syringe time box and enter the run time using the pop-up keypad.
- Touch the START box to begin operation.



You can repeat the previous steps to send additional manual start commands. The TouchNet can retain up to three manual starts in its command queue. If additional starts are attempted while the command queue is full, a BUSY message will be displayed above the START box. Once the number of start commands decreases to less than three, the message will be removed and the additional start commands can be entered.

### To stop the manual operation...

- Press the STOP box to terminate manually started program operations.



Pressing the CANCEL function key to terminate manual operation will also cancel all flow-managed watering activity.



For detailed information on performing Cancel, Rain Delay, Permanent Rain Hold and Adjust factors, refer Section 7, “Special TouchNet Features.”

### The Manual Switch Screen

The Manual Switch screen, shown in **Figure 46a** will appear when MANUAL is selected from the SWITCH PROGRAMS screen.

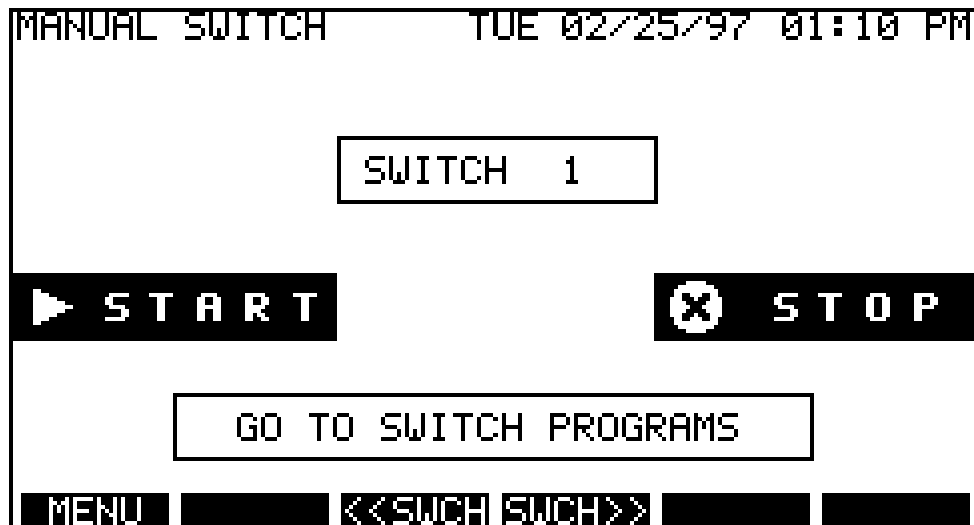

Figure 46a - The Manual Switch screen.

### From the Manual Switch screen you can...

- Manually start and stop operation of specific switches.
- Return to the Switch Programs screen.
- Return to the Menu screen.

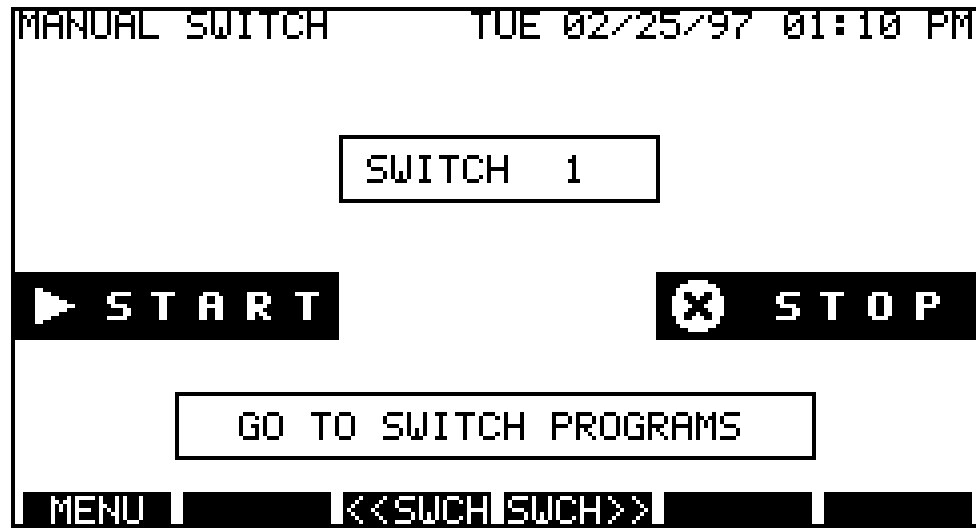

Figure 46b- The Manual Switch screen.

### To operate a switch program manually...

- Select the switch you wish to operate by using the <<SWCH or SWCH>> scroll keys to select the switch program name.
- Touch the START box to begin operation. The switch will operate for its set run time.
- To start additional switch programs, repeat the procedure.



You can repeat the previous steps to send additional manual start commands. The TouchNet can retain up to three manual starts in its command queue. If additional starts are attempted while the command queue is full, a BUSY message will be displayed above the START box. Once the number of start commands decreases to less than three, the message will be removed and the additional start commands can be entered.

### To stop the manual operation...

- Press the STOP box to terminate manually started program operations.



Touching the “Go To Switch Programs” box returns you to the Switch Programs screen.

# Special TouchNet Features

---

The TouchNet provides several features which enable you to further control, review, adjust and monitor your irrigation control system. In this section you will find detailed information on the following TouchNet features:

- Rain Delay
- Cancel
- Adjusting the program run time by percentage and reviewing the changes
- Satellite activity monitor
- Alarms
- Water Window adjustment and review
- User and communications interface utilities

## Rain Delay

The Rain Delay feature enables you to place all watering operations on hold for a period of 1 to 7 days or indefinitely with Permanent Rain Hold.

To select Rain Delay, touch the **RAIN** function key. A pop-up keypad will be displayed.

A prompt on the keypad will ask for the number of rain days you wish to delay watering. The Rain Delay number can be set from 0 to 8. Numbers 1 through 7 will delay watering for that specific number of days. Entering the number 8 will place the TouchNet in Permanent Rain Hold until any number between 0 and 7 is entered. Entering “0” cancels Rain Delay and Permanent Rain Hold, returning the system to normal operation.

Rain delay days are based on watering days established by the specified Day Change, not calendar days.



Selecting Permanent Rain Hold will generate a system alarm. This serves as a reminder that all system operations are indefinitely suspended. See “Alarms”, page 76 for more information.

While the system is in Rain Delay, the “No Watering” icon will be displayed on the Home screen and the Rain function key will change to display the number of days remaining until automatic irrigation resumes.

For example, a 3-day Rain Delay would be displayed as RAIN:3. This number will decrease accordingly at the watering Day Change time.

If Permanent Rain Hold is selected, the Rain function key will be displayed as <RAIN>.

### Cancel All Watering

A “Cancel All” command will stop all irrigation that is currently running and hold any additional programmed sequence starts until the watering schedule is either recalculated and downloaded manually or automatically at the Auto Download Time.

When you touch the CANCEL function key, the Confirm screen shown in **Figure 47** will appear.



**Figure 47** - The Cancel Confirmation screen.

To initiate the Cancel All command, touch the **YES** key. All irrigation activity will be canceled. The Confirm screen will remain displayed until the TouchNet completes the cancel process. The previous screen will then be displayed.

Touching the **NO** key will ignore the Cancel All command. No action will be taken and system operation will not be affected.



While in the Cancel mode, the CANCEL function key will be displayed as <CNCL> and the “No Watering” icon will be displayed on the Home screen.

### Removing the cancel command...

To manually remove the cancel command and return to automatic operation, a manual flow management calculation must be completed and downloaded to the satellites.



- From the system Menu screen touch WATER WINDOW.
- On the Water Window screen, touch the CALCULATE box. During the calculation process, a prompt screen will appear stating “Calculating starts please wait...”



The time required to complete the calculations is determined by the size of the watering schedule data base. Depending on the extent of your irrigation system, it may require several minutes to complete this process.

- Upon completion of the calculation, touch the DNLOAD TO SATELLITES box. A warning screen will appear followed by a prompt screen.
- Follow the instructions provided on these screens to complete the download process.



When the cancel command has been removed, the “No Watering” icon will be removed from the Home screen.

### Adjust Screen

Once the TouchNet is programmed, you can fine-tune the run times of irrigation programs with percentage adjustments. These factors allow you to increase or decrease normal station run times by a percentage from 0 to 250%.

To access the Adjust screen shown in **Figure 48a**, select ADJUST from the Menu screen.

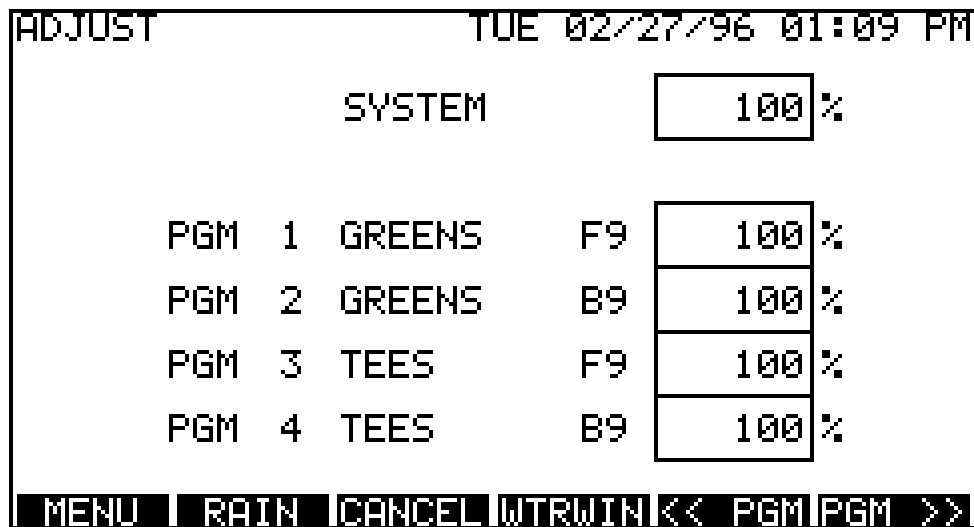
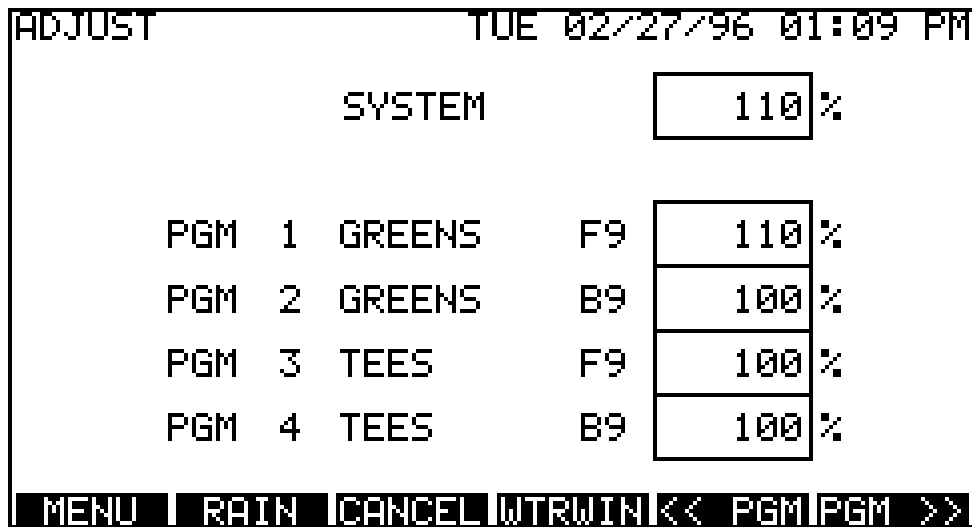

Figure 48a - The Adjust screen.

The SYSTEM percentage adjustment alters run times for every station in the system. The PROGRAM adjustment alters run times for the stations assigned to the specific program.



Adjust factors cannot be applied to Switch programs.



**Figure 48b** - The Adjust screen with data entered.

### To make a percentage adjustment...

- Touch the SYSTEM or desired PROGRAM display box.
- Use the pop-up keypad to enter the percentage adjustment.
- Use the << **PGM** and **PGM** >> keys to scroll through the program list. Make adjustments to all programs as needed.



The Program percentage adjustment does not change when the System percentage adjustment is changed, although the actual station run times for the program are modified.

For example, if stations assigned to the GREENS F9 program have a 17-minute run time, a Program percentage adjustment of 110% would make the actual run time of the stations 18 minutes ( $17 \times 110\% = 18$ ).

If the System was also adjusted to 110%, the stations assigned to the GREENS F9 program would run 20 minutes ( $18 \times 110\% = 20$ ).



If a 0 is entered in the System adjustment box, all system operation will be terminated.

If a 0 is entered in a Program box the program will be terminated.

### Station Review Screen

The Station Review screen, as shown in **Figure 49**, is accessed from the Stations screen and displays the adjusted run time values (A-Time) resulting from changes made on the Adjust screen. As the name indicates, this screen is for review only and does not allow program changes to be made.

**To access the Station Review screen...**

- Touch the STATIONS box on the system Menu screen.
- On the Stations screen, touch the A-TIME box displayed in the upper right corner of the screen. The Station Review screen will appear and the run time column will indicate the adjusted run times.

The Station Review screen example shown in **Figure 49** indicates the adjusted time (A-Time) for these satellite stations has been increased from 17 minutes to 20 minutes resulting from the adjustments made in the Adjust screen.

STATION REVIEW		TUE 02/27/96 01:07 PM			
SAT #	1	HOLES 1 & 18		N-TIME	
	PROGRAM		A-TIME	GPM	FLUGRF
STA 1	GREENS F9		0:20	20	1
STA 2	GREENS F9		0:20	20	1
STA 3	GREENS F9		0:20	20	1
STA 4	GREENS F9		0:20	20	1

MENU | RAIN | << STA STA >> | << SAT SAT >>

**Figure 49** - The Stations screen with data entered.

- To review additional stations and/or satellites, use the << **STA STA** >> and << **SAT SAT** >> scroll keys as needed.
- To return to the Stations screen, touch the N-TIME box.

## Water Window Screen

The Water Window screen, as shown in **Figure 50**, is accessed from the Menu screen by touching WATER WINDOW or from the WTRWIN function key on the bottom of the Adjust and Alarm Conditions screens.

WATER WINDOW		FRI 06/21/96 01:11 PM	
WATER WINDOW START ...		7:00 PM	
WATER WINDOW STOP ....		6:00 AM	
CALCULATED END TIME ..		4:00 AM	
CALCULATE		DNLOAD TO SATELLITES	
IF END TIME LATER THAN STOP LIMIT ....			
ADJUST	<input type="radio"/> WTR ANYWAY	<input checked="" type="radio"/> STOP WTR AT LIMIT	
MENU	RAIN	CANCEL	ALARMS ADJUST STARTS

**Figure 50** - The Water Window screen.

The Water Window screen provides a basic overview of the scheduled watering start and end time for the day. This screen also enables direct interaction with the TouchNet for manual flow management calculations, downloading data to the field satellites and controlling water window parameters.

The term “Water Window” is used to describe the total duration of time allotted for irrigation sequences started on an active watering day. The **potential** Water Window starts when the TouchNet begins the Calculate/Download process (manually or at the specified Auto Download time), and ends upon completion of the last watering sequence started before the watering Day Change time. The **actual** water window starts at the earliest scheduled watering sequence start time and ends at the specified Water Window Stop time.

An override option is provided to enable the actual water window to extend past the Water Window Stop time.

## Water Window Screen Features

### Water Window Start...

Water Window Start Time indicates the beginning of the actual water window and is derived from the first scheduled watering sequence start time entered on the Starts Screen.

### Water Window Stop...

Water Window Stop Time is the specified time when all watering should be finished for the watering day. The default Water Window Stop Time is 5:59 a.m. which is one minute before the default Day Change time of 6:00 a.m. The Water Window Stop Time can be adjusted by touching the time reference box and entering the desired time using the pop-up keypad.



To prevent system Alarm 3, the Water Window Stop Time must be set to occur at least one minute before the Day Change time.

### Calculated End Time...

Calculated End Time is the time of day when all watering is calculated to be finished for the watering day. This time reference is updated whenever a flow management calculation is performed, either automatically at the designated Auto Download time (if selected), or manually when the Water Window CALCULATE box is selected.



To prevent system Alarms 3 and 4, the Calculated End Time must occur before the Water Window Stop Time and the Day Change time.

### If End Time Is Later Than Stop Limit...

If the Calculated End Time is past the specified Water Window Stop Time, the alarm screen will be displayed with an audible signal.

Five options are available from the Water Window screen to resolve the conflict:

- Touching ADJUST to access the Adjust screen where program run times can be decreased globally or individually by specific program.
- Selecting the **Water Anyway** option which enables watering to continue past the designated Water Window Stop Time.
- Selecting the **Stop Water At Limit** option which cancels watering for the remainder of the watering day at the designated Water Window Stop Time.



An Alarm will be generated regardless if the Water Anyway or Stop Water At Limit options are selected.

- Extending the Water Window Stop Time (which may also require extending the Day Change time).
- Accessing the Starts screen where the earliest sequence start can be changed to an earlier time.



To prevent system Alarm 2, the earliest sequence start time must not be set to occur prior to the Auto Download time.

### Calculate

Whenever a change is made to any portion of the watering schedule, a flow management calculation should be made to determine any scheduling conflicts which may result.

Touching the CALCULATE box initiates the calculation process.

During the calculation process, a prompt screen will appear stating “Calculating Starts Please Wait...”



The time required to complete the calculations is determined by the size of the watering schedule data base. Depending on the extent of your irrigation system, it may require several minutes to complete this process.

### Download To Satellites

After the calculation process has been successfully completed, touch the DNLOAD TO SATELLITES box. The prompt screen shown in **Figure 51** will appear.

Upon pressing the DOWNLOAD NOW box, a second prompt screen will appear stating “Downloading to Satellites Please Wait...”

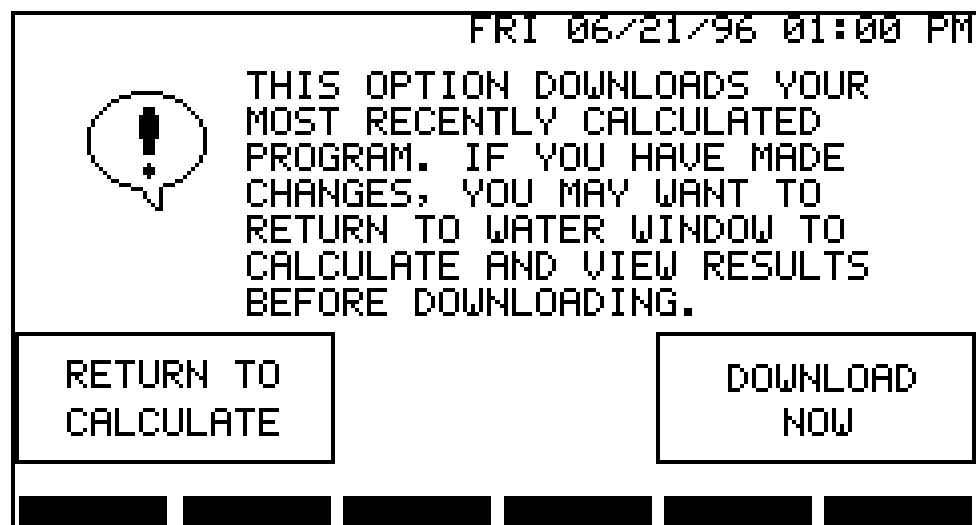
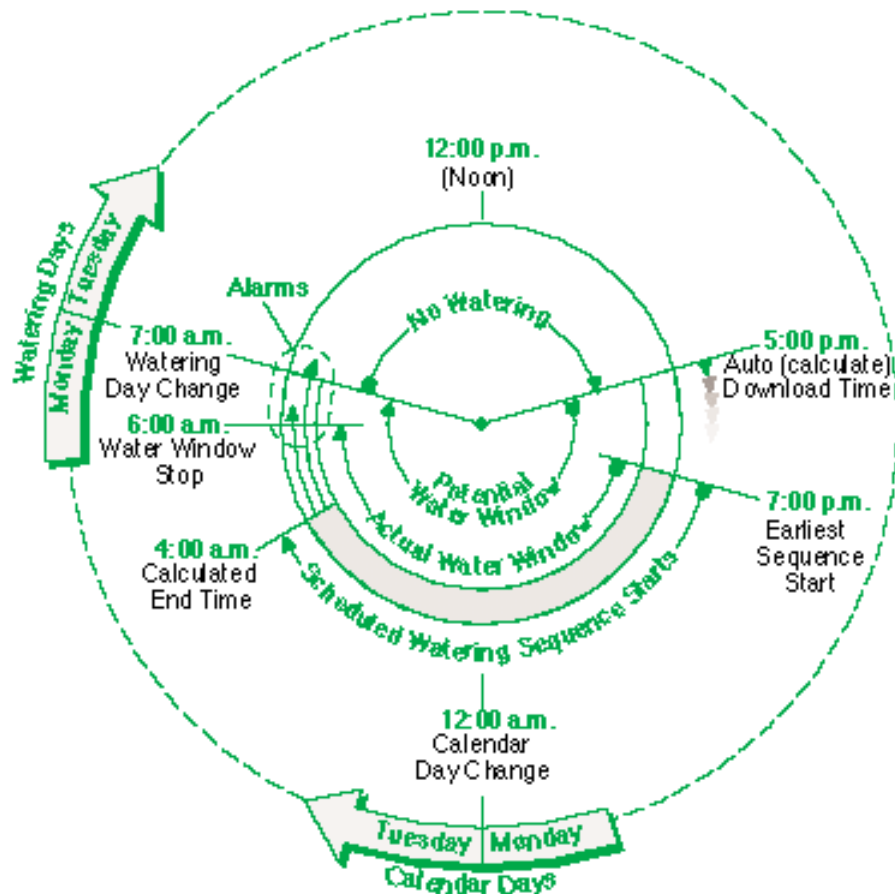

Figure 51 - The Downloads to Satellites Warning screen.

## Watering Schedule Diagram



**Figure 52** - The Watering Schedule Diagram example.

The diagram in **Figure 52** above is provided to help illustrate the various event times and durations of the watering schedule example we have used throughout the programming steps.

In our example, the potential water window starts at the 5:00 p.m. Auto Download time (when flow management calculations are automatically performed and downloaded) and ends at the 7:00 a.m. Watering Day Change time. The actual water window begins at 7:00 p.m. (the earliest scheduled sequence start time) and ends at the 6:00 a.m. Water Window Stop time. The scheduled watering sequences for Monday begin at 7:00 p.m. and end at the Calculated End Time of 4:00 a.m. Monday.

Remember that the Watering Day Change does not occur until 7:00 a.m., so the TouchNet still considers 4:00 a.m. as Monday, not Tuesday, which is the actual calendar day.

All flow managed watering activity will occur during this time. Notice that since the Watering Day Change occurs after midnight, the watering day continues past the Calendar Day Change.





The alarm sound can be enabled once again by touching the checkbox to remove the “X” and touching OK.

Once an alarm has been resolved, the highlight will disappear and the TouchNet will resume normal operation. The Alarm screen will remain displayed until another screen is selected.

The following is a description of each alarm and the recommended procedure(s) to resolve the problem.

### **Alarm 1: System Is In Permanent Rain Hold**

When the TouchNet is put into Permanent Rain Hold, an alarm is generated to remind you that no irrigation will take place while the system is in this mode.

### **Alarm 2: Auto Download Time Is In The Water Window**

The Auto Download process must start at least one minute (recommended one hour) before the first scheduled watering sequence start time. This alarm will be generated if the Auto Download time selected will occur after the first scheduled watering sequence start time, **or**, if the sequence start time selected will occur before the specified Auto download time. Both of these conditions will place the Auto Download time within the Water Window.

To resolve the alarm, reset the Auto Download time to occur before the first sequence start time or reset the first sequence start time to occur after the Auto Download time.

### **Alarm 3: Watering Cycle Ends Past Limit**

An alarm will be generated if the cumulative operating time of all satellite stations programmed for the watering day exceeds the actual Water Window time.

To resolve the alarm, use one or more of the following options:

- Decrease the program run time, number of repeats or soak time.
- Change to an earlier first start time.
- Extend the Water Window Stop time (which may also require extending the Day Change time).
- Select the Water Anyway option.



All flow-managed irrigation control data (regardless of duration) is downloaded to the satellites except any sequence start times which would occur after the watering Day Change time. Selecting the Water Anyway option enables the data to be downloaded and utilized by the satellites.

### **Alarm 4: Watering Cycle Ends Past Day Change**

An alarm will be generated if the calculated watering cycle will end beyond the Watering Day Change time.



If this situation occurs, all watering start times for the day will be ignored and no watering will occur for the watering day.

To resolve Alarm 4, use the same optional procedures listed for Alarm 3.

### **Alarm 5: Too Many Events To Schedule**

If more stations have been scheduled to operate within a watering day than can be properly managed by the TouchNet, this alarm will be generated. Since the TouchNet can calculate 6,500 station events, this alarm is rare.

To resolve the alarm, reschedule your irrigation cycle to run fewer stations per watering day.

### **Alarm 6: Station Violates Flow Limit**

If the station flow is greater than the flow capacity of the System or the assigned Flow Group, this alarm will be generated. If this occurs, the run time of the station in violation will be set to “0” which will prevent its operation.

To resolve the alarm, scroll through the station information on the Stations screen to locate the station(s) which have been reset to “0” run time. Reset the desired run time and the flow to a value which is equal to or less than the System and Flow Zone capacity.

### **Alarm 7: Last Command Incomplete**

If the communication link between the TouchNet and a satellite is interrupted or cannot be established, this alarm will be generated.

The cause of the disruption may be mechanically related, such as damaged communication cable, or because the satellite may be turned off in the field, etc.

To resolve the alarm, ensure the communication cable between the TouchNet and satellite is in good condition. Also ensure the satellite has power.

If the TouchNet is displaying Alarm 7, touch the SAT MON button on the Alarms screen so the non-responding satellite(s) can be identified. See “Satellite Monitor Screen” on page 85 for more information.

### **Alarm 8: Download Not Complete**

If the TouchNet is unable to download program data to a satellite, the download is considered incomplete and this alarm will occur. If the failure is due to satellite non-response, Alarm 7 will also occur at the same time. If Alarm 8 is the only active alarm, try turning the power off to the TouchNet to clear any software errors that may be causing the condition.

## Utilities Screen

The Utilities Screen provides access to several TouchNet interface utilities and setup features. To access the screen shown in **Figure 55**, select UTILITIES from the Menu screen.



The Commercial application Utilities screen is shown. The Golf application setup screen is identical with the exception of the communication setup options.

UTILITIES		FRI 06/20/97 01:00 PM	
BRIGHTEN DISPLAY	DIM DISPLAY		
	DISPLAY TIMEOUT	10 MIN	
	START DATA TRANSFER		
CLEAR USER DATA----		→ <input type="text"/>	
COMMUNICATIONS SETUP:			
<input type="text" value="WIRELINE"/>	<input type="text" value="RADIO"/>	<input type="text" value="TELEPHONE"/>	
MENU RAIN CANCEL MANUAL ADJUST SATMON			

Figure 55 - The Utilities screen (Commercial application).

### To change the display brightness...

Touch the “Brighten Display” or “Dim Display” screen areas increase or decrease the screen brightness level.

### To set screen saver time...

“Display Timeout” is a screen saver utility which will automatically darken the screen after a defined period of inactivity. To change the default time of 10 minutes, touch the Display Timeout box and use the pop-up keypad to enter a timeout duration of 1– 60 minutes. Enter a “0” to disable this feature.

### Start Data Transfer

The Start Data Transfer feature is used when uploading and downloading program data between the TouchNet and a PC. Its use is not covered in this manual. Contact your local Toro distributor for assistance with this feature.

## Communications Setup

A communications setup screen is provided for each of the communication types. Each communications interface will use the setup parameters from its associated screen.

To access the applicable setup screen, touch the WIRELINE, RADIO or TELEPHONE box under Communications Setup.



The Telephone setup option is available in the Commercial application only.

### About the Wireline Setup Screen...

The default setup parameters for wireline communication is shown in **Figure 56**. To change a value, touch the desired parameter value and enter the new value using the pop-up keypad. When finished, touch **OK** to enter the changes, or touch **ESCAPE** to exit the screen without changing changes.

WIRE LINE SETUP		FRI 06/20/97 01:00 PM	
LEAD TONE DURATION	0.015	sec	
RETRIES	3		
CONNECTION TIMEOUT	6	sec	
POLLING INTERVAL	10	sec	
POLLING START TIME	12:00	AM	
POLLING END TIME	12:00	AM	
OK		ESCAPE	

Figure 56- The Wire Line Setup screen.

### Lead Tone Duration

This is the duration of the carrier transmission before data is sent. This can be adjusted from 0.015 to 4.0 seconds in 0.001-second increments. The default is 0.015 seconds.



The lead tone is transmitted immediately after power up, at the start of an irrigation schedule download or after being modified. Global commands broadcast to all system satellites will use the lead tone value established in the Radio Setup screen as shown in **Figure 57**.

### Retries

This is the number of attempts TouchNet will make to communicate with the satellite before declaring the satellite non-responsive. The range of retries is 1 to 10 with a default of 3.

### Connection Timeout

If the channel is busy, TouchNet will wait for the Connection Timeout value before skipping its polling cycle. The duration can be set from 6 seconds to 5 minutes using 1-second increments. The default value is 6 seconds.

### Polling Interval

This is the interval between normal polling cycles and can be set from 10 seconds to 5 minutes in 1-second increments. The default value is 10 seconds.

### Polling Start and End Times

These are the times of day when TouchNet will start and stop polling the satellite. The default for both is 12 a.m. (midnight) which establishes a 24-hour polling window.

### About the Radio Setup Screen...

The default setup parameters for radio (Radio-Link™) communication is shown in **Figure 57**. To change a value, touch the desired parameter value and enter the new value using the pop-up keypad. When finished, touch **OK** to enter the new data, or touch **ESCAPE** to exit the screen without changes.

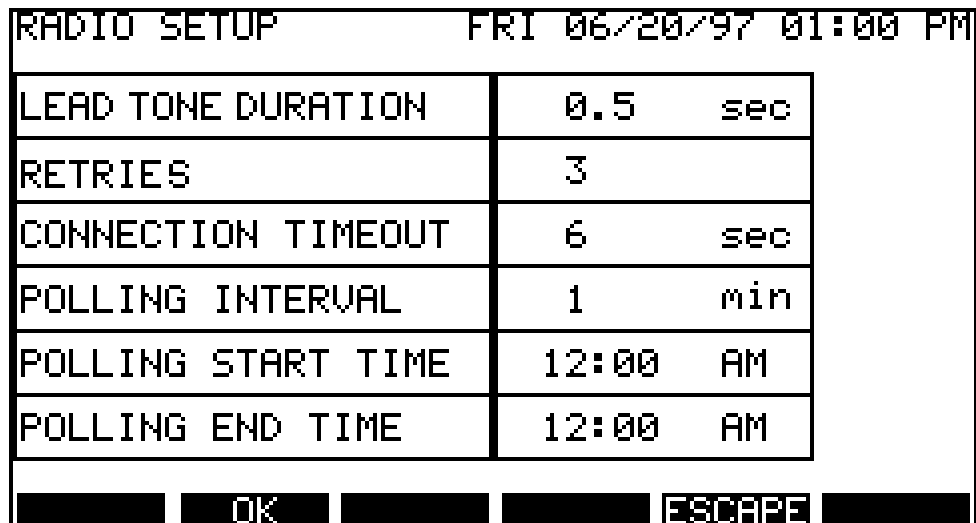

The screenshot shows a terminal-style interface for 'RADIO SETUP'. At the top right, it displays 'FRI 06/20/97 01:00 PM'. Below this is a table with six rows, each representing a parameter and its current value. At the bottom, there are two buttons labeled 'OK' and 'ESCAPE'.

RADIO SETUP		FRI 06/20/97 01:00 PM	
LEAD TONE DURATION	0.5	sec	
RETRIES	3		
CONNECTION TIMEOUT	6	sec	
POLLING INTERVAL	1	min	
POLLING START TIME	12:00	AM	
POLLING END TIME	12:00	AM	

OK      ESCAPE

**Figure 57** - The Radio Setup screen.

### **Lead Tone Duration**

This is the duration of the carrier transmission before data is sent. The Lead Tone is adjustable from 0.015 to 4.0 seconds in 0.1-second increments. The default is 0.5 seconds.



The lead tone is transmitted immediately after power up, at the start of an irrigation schedule download or after being modified. Global commands broadcast to all system satellites will use the lead tone value established in the Radio Setup screen as shown in **Figure 57**.

### **Retries**

This is the number of attempts TouchNet will make to communicate with the satellite before declaring the satellite non-responsive. The range of retries is 1 to 10 with a default of 3.

### **Connection Timeout**

If the channel is busy, TouchNet will wait for the Connection Timeout value before skipping its polling cycle. The duration can be set from 6 seconds to 5 minutes using 1-second increments. The default value is 6 seconds.

### **Polling Interval**

This is the interval between normal polling cycles and can be set from 1 minute to 24 hours in 1-minute increments. The default value is 1 minute.

### **Polling Start and End Times**

These are the times of day when TouchNet will start and stop polling the satellite. The default for both is 12 a.m. (midnight) which establishes a 24-hour polling window.

## About the Telephone Setup Screen...

Telephone communication is available to the TouchNet when operating only in the Commercial application.

The default setup parameters for telephone communication is shown in **Figure 58**. To change a value, touch the desired parameter value and enter the new value using the pop-up keypad. When finished, touch **OK** to enter the new data, or touch **ESCAPE** to exit the screen without changes.

TELEPHONE SETUP		FRI 06/20/97 01:00 PM	
RETRIES	3		
CONNECTION TIMEOUT	60	sec	
POLLING INTERVAL	1	min	
HANG UP TIME	3	sec	
POLLING START TIME	12:00	AM	
POLLING END TIME	12:00	AM	
OK		ESCAPE	

**Figure 58** - The Telephone Setup screen.

### Retries

This is the number of attempts TouchNet will make to communicate with the satellite before declaring the satellite non-responsive. The range of retries is 1 to 10 with a default of 3.

### Connection Timeout

If the channel is busy, TouchNet will wait for the Connection Timeout value before skipping its polling cycle. The duration can be set from 6 seconds to 5 minutes using 1-second increments. The default value is 60 seconds.



The connection timeout period for telephone modem includes the time connecting to the local modem and the remote modem (dial attempt) plus the time for the satellite response (answer timeout).

### Polling Interval

This is the interval between normal polling cycles and can be set from 1 minute to 24 hours in 1-minute increments. The default value is 1 minute.

### Hang Up Time

This is the amount of time allotted to the modem to terminate communications after data transfer has been completed. The range for this setting is 1 second to 5 minutes in 1-second increments. The default value is 3 seconds.

### Polling Start and End Times

These are the times of day when TouchNet will start and stop polling the satellite. The default for both is 12 a.m. (midnight) which establishes a 24-hour polling window.

### Clear User Data

This utility enables initialization of the TouchNet operating system and subsequent elimination of all all user-defined program data returning the TouchNet to its original default parameters.



Performing this operation permanently erases all user-defined program data.

Touch Clear User Data to access the Confirm Clear screen as shown in **Figure 59**.

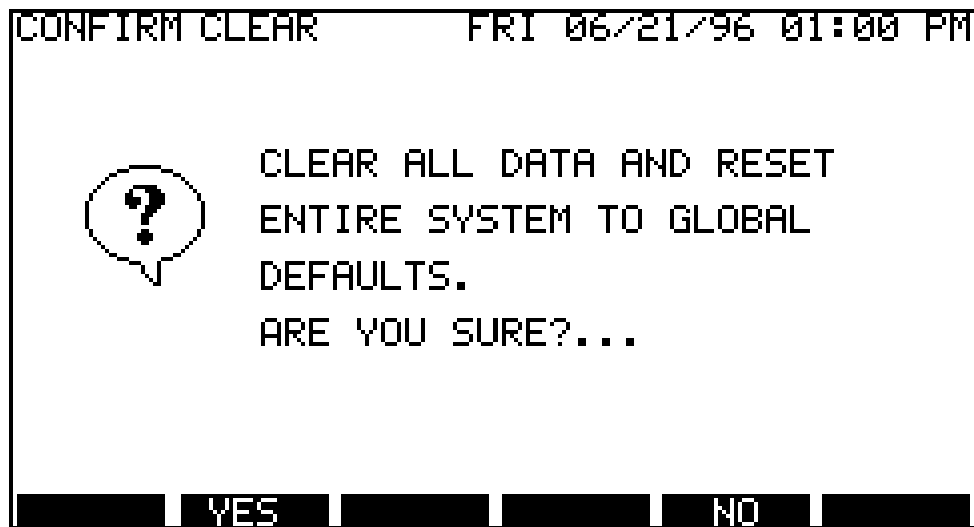

**Figure 59** - The Confirm Clear screen.

- Touch **YES** to clear the data. The System Type screen will be displayed upon completion of the process.
- Touch **NO** to retain the data and return to the Utilities screen.



The “Flow Units” settings will not be affected by this procedure.



## Satellite Monitor

The Satellite Monitor is a convenient utility which enables you to easily access current satellite operational status and program data. The Satellite Monitor screen displays satellite address numbers and indicates (with a circle/slash) any satellite address which has encountered a communication error during the last calculate and download operation. The example screen shown in **Figure 60** indicates satellite #17 and #28 encountered a communication error.

SAT MONITOR						FRI 06/21/96 01:00 PM					
1	2	3	4	5	6	7	8	9	10	11	12
13	14	15	16	<b>(17)</b>	18	19	20	21	22	23	24
25	26	27	<b>(28)</b>	29	30	31	32	33	34	35	
<b>MENU</b>						<b>RAIN CANCEL CHECK1 CHECK2 CHECK3</b>					

Figure 60 - The Satellite Monitor screen.



The Alarm screen will display Alarm 7: “Last Command Incomplete” if a communications error occurs during an automatic download. Unless Alarm 8: “Download Not Complete “ is also generated, Alarm 7 will not be displayed until returning to the Menu screen.

To select a satellite to review, first touch the address number to highlight it (example:#17); then touch the Check screen key you wish to access:

**Check 1 Satellite Status:** Review current operating status and recent satellite activity.

**Check 2 Program/Satellite:** Review program start times and syringe run time (if applicable).

**Check 3 Program/Station:** Review station run time and status by program assignment.



Accessing any Check screen causes the most current program data for the selected satellite to be uploaded to the TouchNet. For Wireline and Radio communications, up to 25 seconds may be required to complete the data upload process; Telephone communications may require up to 1 minute. During this time, the Sat # label will blink intermittently.

## Check 1 Satellite Status Screen

An example of a typical Check 1 Satellite Status screen is shown in **Figure 61** below.

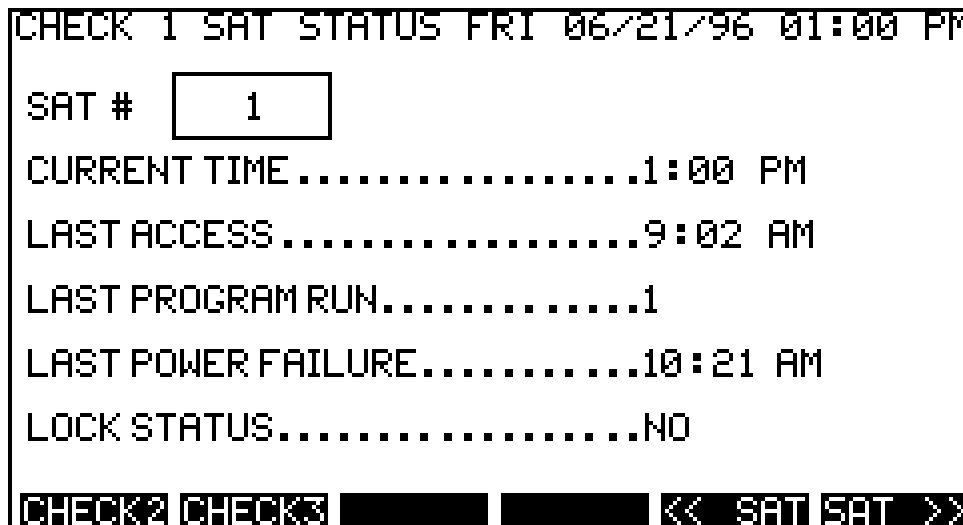

**Figure 61** - The Check 1 Satellite Status screen.

This screen enables you to review the status of the following satellite data:

**Sat #** – The satellite address number being monitored. To access a different satellite address, touch the address box and use the pop-up keypad to enter the desired address number or use the << **SAT** or **SAT**>> keys at the bottom of the screen.



When accessing satellite information, the Sat # label will blink intermittently during the polling and upload process.

If during the upload process, the satellite does not respond to the TouchNet, a communication error message will be displayed next to the satellite address box. For telephone modem and radio communications, the messages include: “Telephone Busy”, “No Dial Tone”, “No Carrier” and “No Answer”. The messages “No Response” or “Connection Busy” will be displayed for all other communication errors.

**Current Time** – The current time the satellite has in its memory.

**Last Access** – The last time one of the satellite timing mechanism control buttons was pressed.

**Last Program Run** – The program number which ran last on this satellite.



If the last satellite operation was a multi-manual start, the value displayed for “Last Program Run” will be “\*”.

**Last Power Failure** – The time of day when power was last removed from this satellite.

**Lock Status** – Indicates whether the satellite lock is on (YES) or off (NO).



To return to the Satellite Monitor screen, you must first access the Check 3 screen, then touch the **SATMON** key.

### Check 2 Program/Satellite Screen

The Check 2 Program/Satellite screen as shown in **Figure 62**, displays start times of the irrigation and switch programs (#9 and/or #10) in addition to syringe run times (if applicable) assigned to the specified satellite. The start times are listed in order, left to right starting in the top left corner.

CHECK 2 PROG/SAT FRI 06/21/96 01:00 PM					
SAT #		6	PROG #		1
START TIME	,SYR	START TIME	,SYR	START TIME	,SYR
7:00 PM,		9:20 PM,		,	
,		,		,	
,		,		,	
,		,		,	
CHECK 1 CHECK 3 <<PROG PROG>> << SAT SAT >>					

**Figure 62** - The Check 2 Program/Satellite Status screen.

To access a different satellite address and/or program number, touch the applicable box and use the pop-up keypad to enter the address or program number, or use the << **SAT** or **SAT**>> and <<**PROG PROG**>> keys at the bottom of the screen.



When accessing satellite information, the Sat # label will blink intermittently during the polling and upload process.



To return to the Satellite Monitor screen, you must first access the Check 3 screen, then touch the **SATMON** key.

## Check 3 Program/Station Screen

The Check 3 screen, as shown in **Figure 63** shows the run time and current status of the satellite stations by program assignment including switch programs.

CHECK 3 PROG/STA FRI 06/21/96 01:00 PM					
SAT #	<input type="text"/>	PROG #	<input type="text"/>	<<STA	STA>>
STATION	RUN	STATUS	STATION	RUN	STATUS
[ 1 ]			[ 5 ]		
[ 2 ]			[ 6 ]		
[ 3 ]			[ 7 ]		
[ 4 ]			[ 8 ]		
<b>CHECK 1 SATMON &lt;&lt;PROG PROG&gt;&gt; &lt;&lt; SAT SAT &gt;&gt;</b>					

**Figure 63** - The Check 3 Program/Station screen.



To access a different satellite address and/or program number, touch the applicable box and use the pop-up keypad to enter the address or program number, or use the <<SAT or SAT>> and <<PROG or PROG>> keys at the bottom of the screen.

If accessing another satellite, the Sat # label will blink intermittently during the satellite polling and upload process.

With program number 1–10 selected, the programmed run times for the stations assigned to that program are displayed. If the program is currently running, an “R” is displayed in the Status column and the remaining run time for each station is displayed.

Eight stations can be displayed at one time. To access additional stations, touch <<STA or STA>> to scroll forward or backward through the station list.

Enter a “0” in the program box to display the remaining station run times for all programs that are currently operating. The status of each station is shown in the “Status” column as follows:

- “A” plus the program number indicates the station was automatically started by that program.
- “M” indicates the station was started manually.
- “S” plus the program number represents an automatically started syringe run time for that program.
- “MM” indicates the station was started with a Multi-Manual program.



Multi-Manual operation is accessible only through direct satellite stand-alone mode or through the Network Hand-Held Remote optional accessory.

To exit the Check 3 screen and access the Satellite Monitor screen, touch the **SATMON** key at the bottom of the screen.

## Appendix A –Troubleshooting

If the following troubleshooting solutions do not resolve the problem, or you experience a problem not covered in this section, contact an authorized Toro distributor for assistance.

### **The power indicator light does not illuminate when the On/Off switch is in the On position.**

- Ensure the power supply is plugged into an outlet and the outlet has power.
- Ensure the power supply cord is plugged firmly into the TouchNet receptacle.

### **No display appears on the screen.**

- Ensure the power indicator light is on and the On/Off switch is in the On position.
- If the power indicator light does not come on, refer to the solutions above.
- If the power indicator light is on, touch any part of the display screen. The TouchNet screen is designed to dim after a brief period of non-use.

### **A program will not run.**

- Ensure the program is part of a sequence start and the start has an active day schedule.
- If the program is part of a start sequence, ensure the priority is not set to “0”.

### **A satellite will not operate.**

- Ensure the check box on the satellite screen for the satellite address has an “X” showing and that it has been assigned to the proper communications medium.
- Ensure ALL communications media connections and setup parameters are properly configured.
- Ensure the satellite stations are assigned to a program, and the program is part of a sequence start.
- Ensure the station run times are not set to “0”, (using either normal or syringe run time).
- Ensure the flow rate of a station does not exceed the set flow capacity of the assigned Flow Group.
- Ensure the hydraulics parameters are proper.



For information on resolving alarms, refer to “System Alarms” on page 76.

## Appendix B –Specifications/Accessories/FCC Rules

### Cabinet

**Dimensions:**

13-1/2" L x 4-3/4" H x 10-3/8" W  
(34.3cm L x 12.1cm H x 34.9cm W)

**Construction:**

ABS plastic suitable for installation within a sheltered location protected from direct exposure to heat and moisture.

**Environmental:**

Operating temperature: 0° to 40° C (32° to 104° F)

### AC Power Supply

UL-listed, CSA-certified, NEC Class 2, SAA-approved, VDE (TUV)-Licensed, CE-Compliant  
Input: 100–250 V a.c., 50/60 Hz, 0.38A, ± 10%  
Output: 12 V d.c., 1.5A

### Optional TouchNet for LTC Communication Accessories

Hand-Held Remote Interface, Model No. HHR-00, HHR-01 or HHR-02

Serial Port Interface Kit, Model No. 89-9065 (required for use with Hand-Held Remote Interface and Telephone Modem)

Radio-Link Interface Kit, Model No. 89-7384

**Note:** The Hand-Held Remote Interface can only be used when TouchNet is operated in the Golf application mode. The Telephone Interface can only be used when TouchNet is operated in the Commercial application mode.

### Electromagnetic Compatibility

**Domestic:** This equipment has been tested and found to comply with the limits for a FCC Class A digital device, pursuant to part 15 of the FCC Rules. These limits are designed to provide reasonable protection against harmful interference when the equipment is operated in a commercial environment. The equipment generates, uses, and can radiate radio frequency energy and, if not installed and used in accordance with the instruction manual, may cause harmful interference to the radio communications. Operation in a residential area is likely to cause harmful interference in which case the user will be required to correct the interference at his own expense.

**International:** This is a CISPR 22 Class A product. In a domestic environment, this product may cause radio interference, in which case the user may be required to take adequate measures.

## Appendix C – Glossary

**Automatic Download (Update Time)** The time when TouchNet develops the station activity schedule for the next irrigation cycle and communicates data to the satellites. This is established on the Setup screen and is recommended to be at least one hour prior to the first irrigation start time.

**Calculated End Time** This is the time when irrigation will end as derived by TouchNet flow management calculations that take into consideration run times, start times, repeats, soak time and flow variables.

**Cancel** Causes the immediate cancellation of all irrigation activity. The TouchNet flow management system ensures an orderly shutdown of the irrigation system to avoid “water hammer” and subsequent hydraulic component damage. The “No Watering” icon will be displayed on the Home screen while the cancel command is in effect.

**Communication Medium** The type of hardware (wireline, radio or telephone modem) utilized for central/satellite communications.

**Event** A satellite station operation.

**Flow Group** A term used to define an area in the hydraulic system that should be restricted to a maximum flow.

**Interval Mode** An active day schedule which is set to a fixed period of days (1 to 30). Programs can be defined to run every day, every other day, every third day, etc.

**Master Sequence** A group of prioritized programs that has an assigned start time, active day(s) and priority number.

**Max Sim Pgms** Maximum Simultaneous Programs. The maximum number of programs (implemented by the TouchNet central) that can run at one time on a satellite.

**Percentage Adjustment** Modifies station run times by multiplying the run time by a specified percent adjustment. For example, a percentage adjustment of 90% will change a normal station run time of 10 minutes to 9 minutes ( $10 \times 90\% = 9$ ).

**Permanent Rain Hold** Delays irrigation activity indefinitely. This occurs when “Rain Days” is set to 8. Watering will not occur until “Rain Days” is reset by touching the RAIN button.

**Rain Delay** Allows the currently selected irrigation activity to finish normally and then holds the subsequent activity for the specified duration.

**Run Time** The duration of time a program/station is set to operate.



## Appendix C – Glossary

**Satellite** An irrigation system controller which has the capability of being operated by a centrally located control unit.

**Sequence Start Time** The time of day specified to start a Master Watering Sequence.

**Station** The term used to describe one controlled 24 V a.c. output source of an irrigation system controller.

**Switch Program** A non-irrigation program used for the operation of switch-controlled devices.

**Syringe** A setting of 1 to 30 minutes that can be set to override a specified program run time. Generally used for short, temporary watering operations for frost/dew removal, heat stress prevention or system testing.

**Watering Day** The watering day is a 24-hour period of time in which watering is scheduled. Since the watering day change time can be specified, it may not be the same as the calendar day which changes at 12:00 a.m. (midnight).

**Water Window** The term Water Window is used to describe the total duration of time allotted for irrigation sequences on an active watering day.

**Water Window (Actual)** The period of time during which watering automatically occurs. The watering cycle begins when the first station starts to water and ends when the last station has finished.

**Water Window (Potential)** The potential Water Window starts when the TouchNet has completed the Calculate/Download process (manually or at the specified Auto Download time), and ends upon completion of the last watering sequence started before the Watering Day Change time.



**Notes:**



## Network LTC™ Satellite Field Data Worksheet

<b>Satellite No.</b>	
<b>Name/Area</b>	
<b>Max Sim Pgms</b>	
<b>Flow Group</b>	

Switch Program #	Start Times			
	Start 1	Start 2	Start 3	Start 4

Sta.	Program	Time	Flow	Group
1				
2				
3				
4				
5				
6				
7				
8				
9				
10				
11				
12				
13				
14				
15				
16				
17				
18				
19				
20				
21				
22				
23				
24				
25				
26				
27				
28				
29				
30				
31				
32				

Sta.	Program	Time	Flow	Group
33				
34				
35				
36				
37				
38				
39				
40				
41				
42				
43				
44				
45				
46				
47				
48				
49				
50				
51				
52				
53				
54				
55				
56				
57				
58				
59				
60				
61				
62				
63				
64				