



INSTALLATION & SERVICE INSTRUCTIONS

690 Series Rotary Sprinkler

Introduction

The 690 Series Rotary Sprinkler is designed for irrigation of large turf areas such as golf courses, parks, recreational fields and school grounds.

Manufactured from durable, high strength engineering plastic and stainless steel components, the 690 sprinkler incorporates many innovative and time proven features for lasting, maintenance-free operation. Some of these features are listed below.



Model 69X-06-XX



Model 69X-01-XX



Model 69X-02-XX

Specifications

- 78 ft. – 108 ft. Radius
- Pop-Up Nozzle and Cap - $\frac{7}{8}$ in.
- 1½ in. NPT Female Thread Inlet
- Recommended Operating Pressure: 60 – 100 PSI
- Maximum Pressure: 150 PSI
- Electric Models:
 - Solenoid - 24 VAC
 - Inrush Current - .42 Amps
 - Holding Current - .21 Amps
- Dimensions:
 - Cap Diameter - 7½ in.
 - Flange Diameter - 10 in.
 - Height - 16 in.

Features

- **Positive Spring Retraction** - Pulls nozzle and cap down out of the way of people and turf maintenance equipment.
- **Three Nozzle Sizes** - Multiple nozzle sizes provide 45.1 to 82.2 GPM flow and produce watering radii from 78 to 108 feet.
- **Long Life Gear Drive** - Gear drive mechanism is vacuum-packed with lubricant and isolated from water stream for long, trouble-free life.
- **Valve-In-Head Models** - Permits head-by-head control to customize turf watering for various topography and soil conditions. Multi-cycle for wind or runoff problems, frost control and dew removal without low-head drainage. Available for hydraulic normally open or 24 Volt electric systems.
- **Sprinkler Operating Mode** - Electric valve-in-head models have three modes of operation; AUTO, ON and OFF. Mode is set using a selector tool inserted through the sprinkler body flange.
- **Built-in Check Valve** - Check-o-matic sprinklers utilize a check valve in the sprinkler base to prevent seepage from low area heads after valve closure. Check valve will hold up to 35 feet of elevation differential.
- **Two-Speed / 60°-120° Models** - Provides for more even precipitation. Runs at half speed in non-overlapping areas.
- **Two-Speed / 180° Models** - Provides for more even precipitation where only a selected area is covered by an overlap, such as is found on greens. Runs at half speed in non-overlapping areas.
- **Serviceability** - All internal parts of the sprinkler are accessible through the top of the sprinkler body.

MODEL NUMBER CODE				
69X-XX-XX				
Series	Arc	Cover	Operation	Nozzle Set
69X	1 = Quarter Circle 2 = Half Circle Regular Speed 4 = Full Circle 6 = Two Speed 60°-180° 8 = Two Speed 180°	0 = Standard 1 = Rubber	1 = Valve-in-head Hydraulic N.O. 2 = Checkomatic	-90 = 3/8 in. -91 = 7/16 in. -92 = 1/2 in.

- Conversion Information**
- All gallons per minute shown are U.S.
 - To convert to Imperial gallons per minute, multiply by .833.
 - To convert to litres per minute, multiply by 3.78.
 - To convert pounds per square inch (PSI) to atmospheres, divide by 14.7.
 - To convert pounds per square inch (PSI) to kilograms per square centimeter (kg/cm²) divide by 14.22.
 - To convert feet to meters, divide by 3.28.
 - To convert inches to millimeters, multiply by 25.4.

Performance Chart

Base Pressure	Nozzle Set -90 Size 3/8 in.		Nozzle Set -91 Size 7/16 in.		Nozzle Set -92 Size 1/2 in.	
	PSI	Rad.	GPM	Rad.	GPM	GPM
40						
50						
60	78 ft.	45.1	87 ft.	53.7		
70	82 ft.	48.6	91 ft.	57.2	96 ft.	67.5
80	87 ft.	51.0	96 ft.	61.2	100 ft.	74.0
90	.				105 ft.	78.0
100	* 90 ft.	* 57.1	* 100 ft.	* 73.4	* 108 ft.	* 82.2

* Indicates where pressure regulation begins on electric V-I-H models.

Spacing of Sprinklers

Square Spacing

No Wind	55% of diameter
4 m.p.h.	50% of diameter
8 m.p.h.	45% of diameter

Triangular Spacing

No Wind	60% of diameter
4 m.p.h.	55% of diameter
8 m.p.h.	50% of diameter

Single Row Spacing

No Wind	50% of diameter
4 m.p.h.	50% of diameter
8 m.p.h.	45% of diameter

Installation Procedure

To assure maximum performance from your 690 Series Rotary Sprinklers, read these instructions completely prior to installing or servicing the sprinkler.

Construct Swing Joints

1. Construct triple swing joints for each sprinkler as shown in Figure 1. Use PVC or ABS pipe nipple for sprinkler connection.

Note: On sites where the possibility of heavy equipment rolling over a sprinkler exists, the swing joint will flex preventing damage to the lateral or main lines. On a new installation in raw ground where the sprinklers are to be initially installed above the finished grade and lowered when new turf is established, the swing joint allows sprinkler repositioning without changing risers. This is a common and practical procedure which eliminates the problem of dirt being accidentally introduced into the lateral lines when a riser is changed.

2. Flush lines thoroughly prior to installing sprinkler.
3. Apply Teflon tape on riser threads. Install sprinkler to riser and tighten.

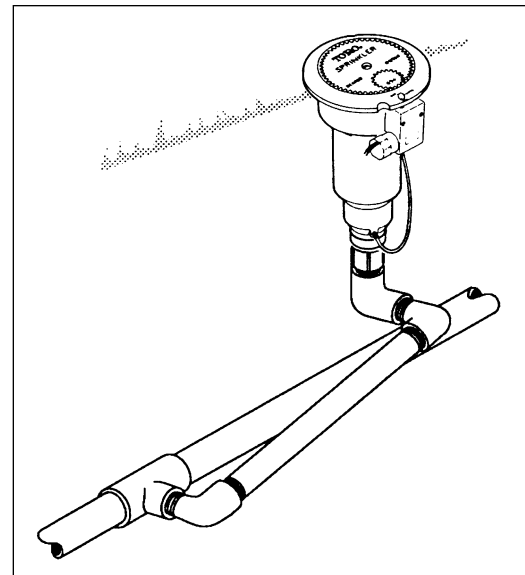

Figure 1
Triple Swing Joints

CAUTION

Use only Teflon™ tape on riser threads. Use of pipe dope or other types of sealing compounds can cause deterioration of sprinkler body threads.

Connecting Electric Control Wires

1. Route control wires to sprinkler location(s). Provide enough extra wire at sprinkler to allow for movement of sprinkler without straining wire connections. One common wire and one station wire are required for each sprinkler. See Wire Sizing Chart, Table 1 for proper application.
2. Attach control wires to solenoid leads using an approved waterproof splicing method.

CAUTION

All wires must be waterproofed to prevent short circuit to ground and subsequent controller damage.

Connecting Hydraulic Control Tubing

1. Route control tubing from controller to sprinkler location(s).

Note: Leave an 18 inch service loop of tubing at each sprinkler to facilitate movement of sprinkler and service operations. Tubing runs in excess of 1,000 feet are not advisable due to delayed response time. The controller for hydraulic valve-in-head systems should never be located more than 25 feet below or more than 70 feet higher than the valves. Although there is no limit to the amount of hydraulic valve-in-head sprinklers controlled by one control station, practical experience suggests the maximum number of heads normally used is five.

2. Flush tubing thoroughly to remove all air and debris.
3. Remove tube retainer and poly cap from tubing adapter at base of sprinkler.
4. Slide tube retainer over control tubing and attach tubing to adapter. Slide tube retainer over adapter area to secure tubing.

System Start-Up

The following is a recommended procedure that will protect system components during system start-up. The procedure is based on a velocity fill rate of less than 2 feet per second. See Table 2 below.

1. Use jockey pump only to fill system at velocity fill rate of less than 2 feet per second.



WARNING

TO PREVENT PERSONAL INJURY, DO NOT STAND DIRECTLY OVER ANY COMMERCIAL OR LARGE TURF HEAD DURING FILL OR WHEN ACTIVATING MANUALLY AT THE HEAD.

2. Use quick coupler keys at all tees and greens with quick coupler valves to bleed air from system lines during filling process. Do not compress air and then relieve - bleed air while filling system.
3. After water has filled all lines and all air is removed, remove quick coupler keys.

CAUTION

Failure to comply with recommended fill rate will increase line pressure resulting in a water hammer effect that could damage sprinklers.

Table 2

Pipe Size Inches	Gallons Per Minute	Velocity - Feet Per Second	Pipe Size Inches	Gallons Per Minute	Velocity - Feet Per Second
1/2	2	1.60	3	45	1.86
3/4	3	1.92	4	75	1.87
1	5	1.50	6	150	1.73
1-1/4	10	1.86	8	250	1.70
1-1/2	10	1.41	10	450	1.97
2	20	1.80	12	500	1.55
2-1/2	30	1.84			

Table 1 - Wire Sizing Chart

Maximum Allowable Length in Feet From Controller to VIH Sprinklers.

VOLTAGE AT CONTROLLER	WIRE SIZE		NUMBER OF VALVES			
	CONTROL	COMMON	1	2	3	4
110 VAC	14	14	2348	1012	549	353
110 VAC	14	12	2890	1239	673	433
110 VAC	14	10	3378	1448	786	505
110 VAC	12	12	3759	1604	873	561
110 VAC	12	10	4591	1973	1071	688
110 VAC	12	8	5411	2328	1263	812
110 VAC	10	10	5945	2555	1387	892
115 VAC	14	14	2765	1309	846	549
115 VAC	14	12	3393	1608	1039	673
115 VAC	14	10	3962	1877	1213	783
115 VAC	12	12	4394	2082	1346	872
115 VAC	12	10	5397	2557	1652	1071
115 VAC	12	8	6364	3018	1949	1263
115 VAC	10	10	6986	3311	2140	1387

Chart based on the following: Transformer - 115 VAC - 124 VAC, 45 VA
Coil Assy. - 24 VAC, 60 Hz
Holding - .21 Amps
In Rush - .42 Amps

Two-Speed Sprinkler Alignment - Models 696 and 698

There are two types of full circle sprinklers which have special arcs of slower than regular speed. Alignment of the heads is critical for proper performance. The model 696 sprinkler is a two-speed head with two 60° and two 120° arcs of speed. A red button on the drive assembly indicates it is a two-speed 60°–120° head and acts as a pointer toward the center of the fairway or the next head in the row of sprinklers. The model 698 sprinkler is a two-speed head with two 180° arcs of speed. A yellow button on the drive assembly indicates it is a two-speed 180° head and also indicates the center of the regular speed side. Align the sprinkler so the button points toward the center of the overlapped area of coverage. When a nozzle assembly is changed on either the 696 or 698 head, the main nozzle must be aligned with the small boss on the bull gear of the drive assembly.

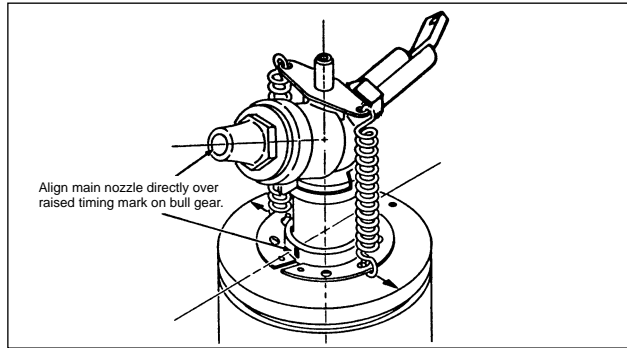

Figure 2 - Nozzle Alignment

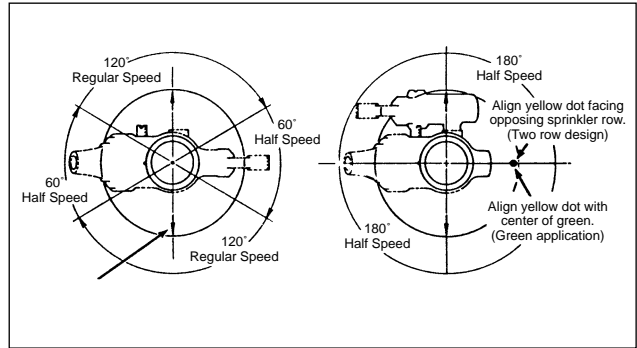
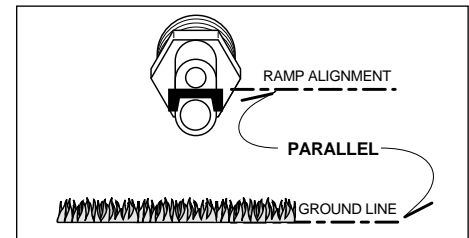

Figure 3 - Alignment of Drive Assembly to Turf Coverage Area

Back Nozzle Alignment

When replacing the back nozzle, align it so the nozzles are vertical and the ramp is parallel to the ground. Use a 5/8 in. wrench to remove and align the back nozzle. See example at right.



Pilot Valve Operation

The main function of the pilot valve is to control the operation of the main valve located in the base of the sprinkler body. The main valve is operated by the release of water metered through the pilot valve when it is activated either manually or automatically by the 24 VAC coil assembly.

Another important function of the pilot valve is to regulate the water pressure to the sprinkler nozzle. Pressure regulation compensates for large variations within the system and maintains a constant pressure for optimum sprinkler operation. The 690 series pilot valve is factory set to regulate at 80 or 100 PSI depending on sprinkler model.

Sprinkler operation mode is set using a Toro Selector Tool (P/N 995-15) inserted through the body flange onto the pilot valve D shaped selector-cam. The "AUTO" mode permits automatic operation from the system controller. The "ON" mode opens the main valve for manual operation and "OFF" mode prevents the main valve from opening.

System Troubleshooting

Pilot Valve

Possible equipment failures with causes and corrective action are listed below.

PROBLEM	POSSIBLE CAUSE – CORRECTIVE ACTION
1. Sprinkler will not turn on	(a) No 24 VAC to coil assembly - Measure voltage with DVM. Check wiring and controller program - Refer to Controller Operating Instructions.
	(b) Selector cam in "OFF" position - Set to "AUTO" position.
	(c) Debris in pilot valve assembly - Disassemble and remove all debris (See Servicing Pilot Valve page 8.)
2. Sprinkler will not shut off	(a) Constant 24 VAC from controller - Check for voltage using a DVM. If voltage is present, disconnect wire. If sprinkler closes, service controller. Refer to Controller Service Manual.
	(b) Selector cam in manual "ON" position - Set to "AUTO" or "OFF" position.
	(c) Debris in pilot valve assembly - Disassemble and remove all debris (See Servicing Pilot Valve page 8.)

System Troubleshooting (continued)

Sprinklers

Possible equipment failures with causes and corrective action are listed below.

PROBLEM	POSSIBLE CAUSE – CORRECTIVE ACTION
1. Sprinkler won't rotate	(a) Stator too large for nozzle - Use proper nozzle. (b) Debris wedged between stator and turbine - Remove obstruction. (c) Drive assembly defective - Replace with new drive assembly.
2. Head sticks up	(a) Dirt in riser assembly - Flush out. (See Flushing Procedure.) (b) Damaged riser - Replace.
3. Poor distribution pattern	(a) Nozzle plugged with debris - Clean or replace nozzle. (b) Nozzle orifice/stream straightener damaged - Replace nozzle. (c) Low operating pressure - Determine why system overloaded and correct. (d) Head misaligned during installation (two-speed only) - Realign properly.
4. Valve won't close (Hydraulic 69X-01-XX)	(a) Leak in control tubing - Isolate and repair. (b) Pilot valve leak in controller - Confirm by observing constant dripping from discharge line of controller. Refer to Controller Service Manual. (c) Foreign object keeping valve from seating - Remove, clean and check valve for damage. Replace if necessary. (d) Damaged piston seal or piston assembly - Replace valve assembly. (e) Valve not properly communicated to tube in body - Reassemble if necessary.
5. Valve won't open (Hydraulic 69X-01-XX)	(a) Plugged controller discharge line or discharge port in pilot valve - Verify by checking for discharge at discharge line when station is activated - If no discharge, refer to Controller Service Manual. (b) Water supply to sprinkler closed off - Determine if closure is shut-off valve or blockage and correct.
6. Valve won't close (Electric 69X-06-XX)	(a) Leak in pilot valve assembly - Replace pilot valve assembly. (b) Plugged supply screen on piston - Clean or replace screen. (c) Manual control selector on pilot valve assembly turned to "ON" position - Turn to "AUTO" position.
7. Valve won't open (Electric 69X-06-XX)	(a) Control (field) wires severed - Isolate and repair. (b) Defective solenoid - Replace solenoid. (c) No power to controller - Establish controller power. (d) No power from controller to solenoid - Check for blown fuse and replace. (e) Manual control selector on pilot valve assembly turned to "OFF" position - Turn to "AUTO" position. (f) No supply from main valve and piston - Remove supply tube from supply port. If no supply port, repair valve and piston assembly.
8. Valve leaks	(a) Damaged or blocked valve seat - Remove blockage and, if necessary, replace valve assembly. (b) Damaged piston seal or piston assembly - Replace valve assembly. (c) Low pressure on supply line on hydraulic NO sprinklers - Check for low pressure reason and correct.
9. Several valves on different stations fail to close (Hydraulic 69X-01-XX)	(a) Control tubing leak which lowers supply pressure to other stations - Turn controller from station to station until a station is reached where only valves on that station stay open. The leak would be in the tubing on that station - Isolate and repair. (b) Leak in supply line to controller - Verify by checking pressure in all control lines. (c) Leak in controller pilot valve - Verify by constant discharge on controller - Refer to Controller Service Manual. (d) Plugged supply line filter - Replace filter if more than 3 psi differential exists.

Servicing Procedures

Introduction

The 690 Series rotary sprinkler is designed to provide the user trouble free operation for many years without scheduled maintenance. Should it become necessary to disassemble the sprinkler to correct a malfunction or replace a component, all internal parts of the sprinkler are accessible from the top. Refer to the Troubleshooting Procedure in this manual in the event of a malfunction. Some special tools are required for disassembly and/or maintenance of the sprinkler and are available from your Toro dealer.



WARNING

TO PREVENT POSSIBLE INJURY DURING SPRINKLER SERVICING PROCEDURES, CONFIRM THE FOLLOWING CONDITIONS EXIST PRIOR TO STARTING.

- A. WATER SUPPLY TO SPRINKLER IS SHUT OFF AT SOURCE.**
- B. SYSTEM PRESSURE IS BLED FROM SYSTEM, INCLUDING CONTROL TUBES.**
- C. A.C. POWER IS DISCONNECTED AT SOURCE**

Servicing Sprinkler Mechanism and Valve Assembly

(Refer to Figure 8 for the following procedure.)

1. Remove rubber cap plug (1) if installed.
2. Remove machine screw (2) and cap (4).
3. Using snap ring pliers (P/N 995-07), remove head snap ring (11).
4. Grasping nozzle base (9), pull sprinkler mechanism out of body.
Note: Due to O-ring seal compression between drive assembly and body, considerable resistance may be felt when removing sprinkler mechanism.
5. Unhook and remove retraction springs (6) from spring strap (5) and spring collar (14).
6. To remove nozzle base assembly, hold riser and riser pliers (P/N 995-17) and turn nozzle base assembly counterclockwise.
7. Using appropriate size end wrenches, turn nozzles counterclockwise to remove from nozzle base.
8. Carefully pull stream straightener (8) out of nozzle base using needle nose pliers.
9. To remove stator (15), insert screwdriver blade between stator and drive assembly housing (13) and pry apart.
Note: A small notch for screwdriver blade insertion is provided on edge of stator.
10. Thoroughly clean and inspect all parts. Replace parts as required.
Note: If changing nozzle to a different size, appropriate stator must also be installed to ensure proper rotation speed and coverage.



WARNING

POSITIVELY SHUT OFF WATER SUPPLY AT SOURCE PRIOR TO REMOVING VALVE ASSEMBLY. BLEED ALL PRESSURE FROM SYSTEM INCLUDING CONTROL TUBES. FAILURE TO DEPRESSURIZE SYSTEM PRIOR TO SNAP RING REMOVAL COULD CAUSE VALVE MECHANISM TO EJECT FROM SPRINKLER BODY UNDER PRESSURE RESULTING IN POSSIBLE SERIOUS INJURY TO PERSONNEL.

11. To remove valve assembly, squeeze ears of snap ring together with snap ring pliers (P/N 995-07) and remove snap ring from sprinkler body. (See Figure 4).

CAUTION

If snap ring is difficult to remove, there may be residual water pressure in the system. Recheck the water supply to insure it is turned off and all pressure has been totally eliminated before removing the snap ring and valve.

12. Use valve removal tool (P/N 995-08) to remove valve assembly from base of sprinkler body. Valve Removal Tool is inserted into sprinkler body and pushed through valve ribs to the underside of valve. A slight twist will lock tool to valve enabling removal by pulling straight up and out. (See Figure 5.)

NOTE: If valve removal tool is not available, use snap ring pliers to grasp rib of valve assembly and pull up and out of sprinkler body.

13. To reinstall valve assembly with snap ring and to prevent damage to the communication tube in sprinkler body, use valve insertion tool (P/N 995-11). Valve insertion tool will automatically line up valve assembly with sprinkler body communication tube and correctly seat the snap ring. (See Figure 6).

NOTE: It is possible to install the snap ring backwards (upside down). See inset in Figure 6 to insure that snap ring is installed in the correct manner.

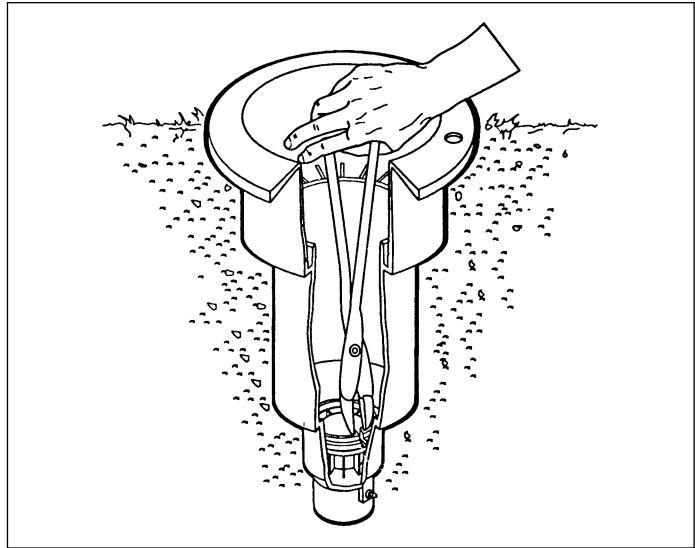

Figure 4
Using Snap Ring Pliers to Remove Snap Ring

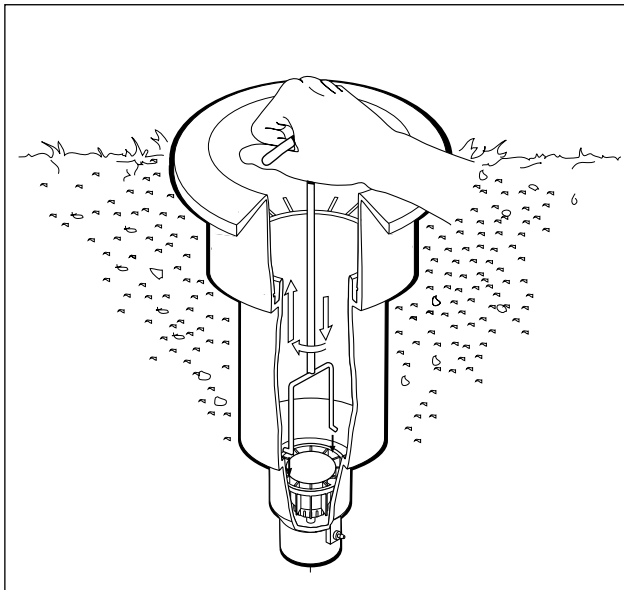

Figure 5
Using Valve Removal Tool to Remove Valve Assembly

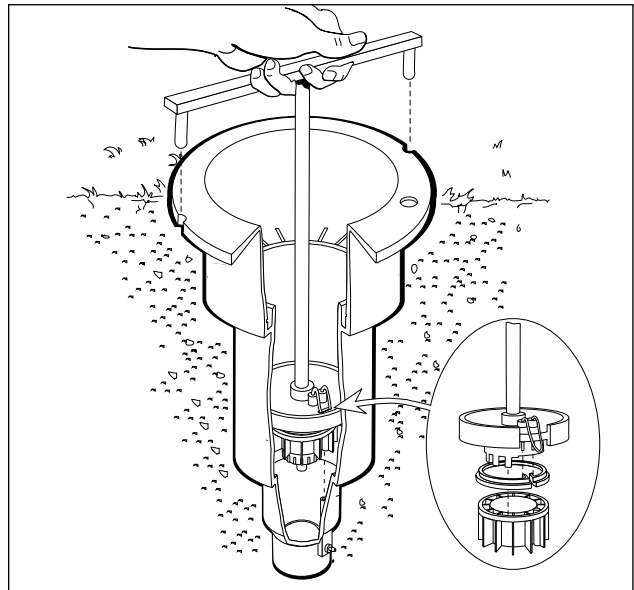

Figure 6
Using Valve Insertion Tool to Install Valve Assembly
with Snap Ring Pliers

Servicing Pilot Valve Assembly

Note: Assure water supply to sprinkler is positively shut off and all residual pressure has been bled. If sprinkler is pressurized, main valve will open when the pilot valve control tube is disconnected.

Refer to Figure 7 for the following procedure.

1. Carefully remove turf and soil from side of sprinkler to expose pilot valve and control tubing.
2. Remove two retaining screws from pilot valve housing.
3. Pull pilot valve assembly away from sprinkler body and cut control tubing just below tube retainer. *Unless pilot valve has been previously removed, control tubing length will be sufficient for re-connection.*
4. Remove tube retainer and remaining piece of control tubing from valve body fitting.
5. Remove solenoid (1) or NC adapter (2) by turning it counterclockwise.
6. Pull pilot valve body assembly (4–12) out of housing.
7. Remove diaphragm assembly (12), piston (11) and spring (10).
8. Remove selector (7) and plunger assembly (5 or 6). *Selector retains plunger in body.*
9. Thoroughly clean and inspect all parts. Replace damaged parts as necessary and reassemble in reverse order.

Figure 7 Pilot Valve, Current

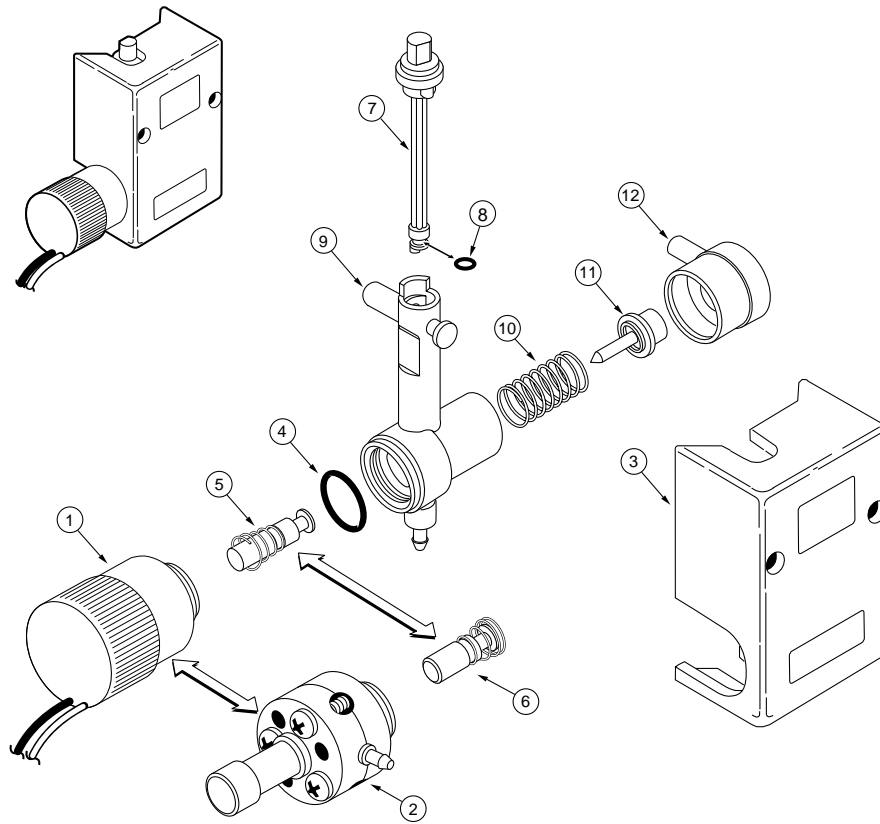

Item No.	Part No.	Nomenclature	Quantity Per Assy.
1	89-1905	Solenoid, Pilot Valve & Valve	1
2	89-6005	Adapter, Pilot Valve, NC	1
3	89-0001	Housing, Pilot Valve	1
4	360-0220	O-Ring, .070" x .551" x .691"	1
5	35-9993	Plunger Assy., Elec.	1
6	89-6003	Plunger Assy., NC	1
7	-----	Selector (See Service Parts and Assemblies below)	1
8	1-2035	O-Ring, .070" x .114" x .254"	1
9	89-6004	Body Assy., Pilot Valve	1
10	35-9970	Spring, 50 lbs., Black	1
10	35-9971	Spring, 65 lbs., Green	1
10	35-9972	Spring, 80 lbs., Red	1
10	35-9973	Spring, 100 lbs., Blue	1
11	89-0029	Piston	1
12	89-0005	Diaphragm Assembly	1
		SERVICE PARTS AND ASSEMBLIES	
	89-0009	Pilot Valve Assy., 50 lbs., Elec.	
	89-0010	Pilot Valve Assy., 65 lbs., Elec.	
	89-0011	Pilot Valve Assy., 80 lbs., Elec.	
	89-0012	Pilot Valve Assy., 100 lbs., Elec.	
	89-3918	Pilot Valve Assy., 50 lbs., NC	
	89-3919	Pilot Valve Assy., 65 lbs., NC	
	89-7125	Pilot Valve Assy., 80 lbs., NC	
	89-7126	Pilot Valve Assy., 100 lbs., NC	
	89-0998	Pilot Valve less Solenoid, 50 lbs., Elec.	
	89-0999	Pilot Valve less Solenoid, 65 lbs., Elec.	
	89-1000	Pilot Valve less Solenoid, 80 lbs., Elec.	
	89-1001	Pilot Valve less Solenoid, 100 lbs., Elec.	
	102-0343	Selector Cam Assy. (Includes Items 7-8)	

Figure 8 690 Series

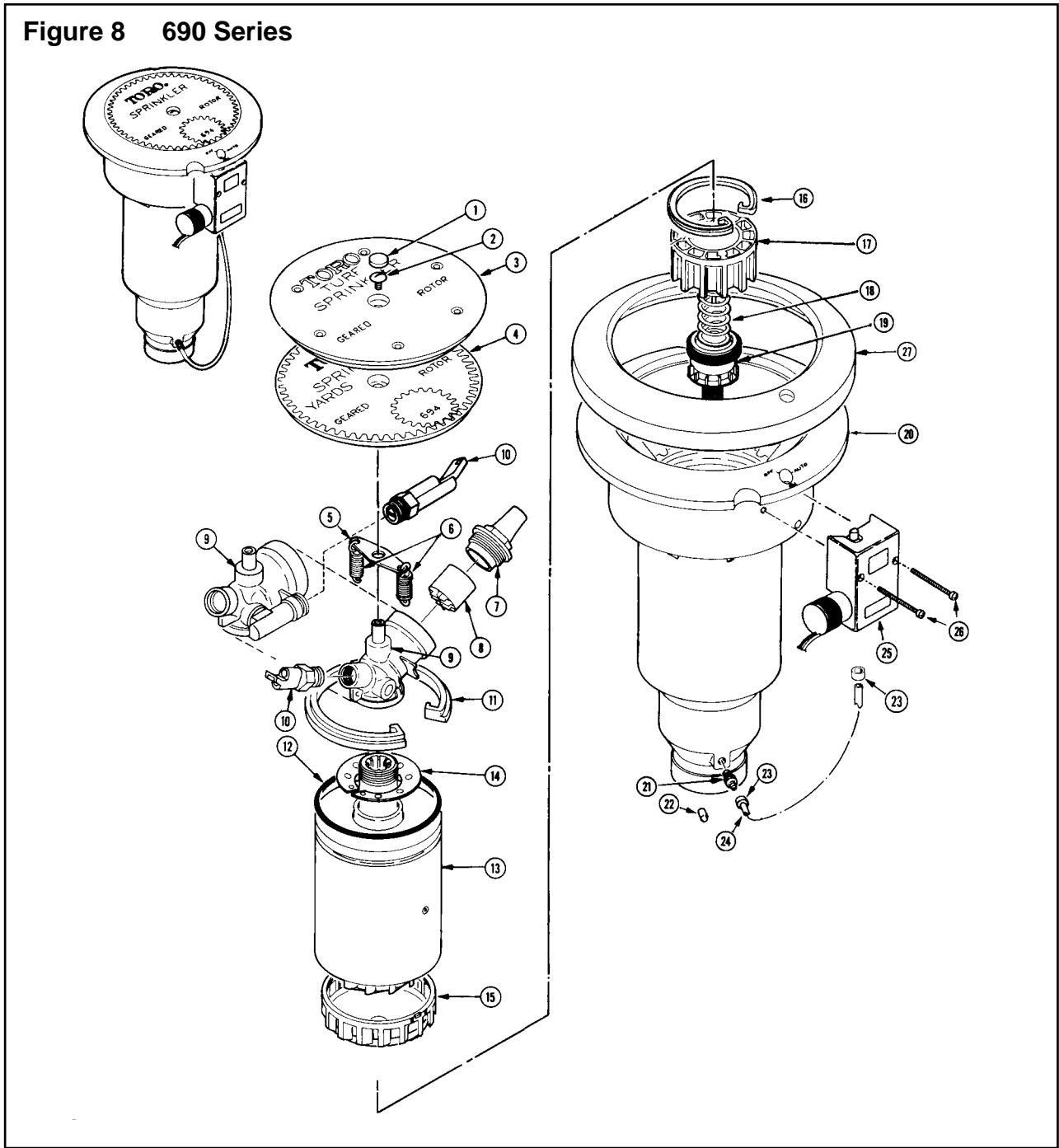

Model Number Information

69X-XX-XXX			
Arc	Body	Nozzle	Pressure Regulation *
1 = 90° Quarter Circle	01 = NPT, NO Valve-In-Head	90	8 = 80 PSI
2 = 180° Half Circle	02 = NPT, Check-O-Matic	91	1 = 100 PSI
4 = Full Circle	06 = NPT, Electric Valve-In-Head	92	
6 = Full Circle, 2-Speed, (60°-120°)	§08 = NPT, NC Valve-In-Head		
8 = Full Circle, 2-Speed, (180°-180°)			
** A = 150°			* Pressure Regulation available on Electric & NC VIH models only.
** B = 165°			** Special arcs not available on Normally Closed (NC) models.
** C = 195°			§ Pre-1998 models only.
** D = 210°			

Item No.	Part No.	Nomenclature	Quantity Per Assy.
1	3-2518	Plug, Cap , Rubber	1
2	3-3567	Screw, Machine, 1/4 - 20 x3/8"	1
3	3-3529	Cap Assy., Rubber Cover (Includes Item 4)	1
-	3-3582	Cover, Cap, Rubber	1
4	3-3532	Cap, Blank	1
5	9-2734	Strap, Spring	1
6	9-2738	Spring, Retraction	2
7	89-5816	Nozzle, Main, 3/8", #90	1
7	3-3542	Nozzle, Main, 7/16", #91	1
7	3-3543	Nozzle, Main, 1/2", #92	1
8	3-3535	Straightener, Stream	1
9	3-3531	Base, Nozzle, Full Circle	1
9	9-1079	Base, Nozzle, Part Circle	1
10	9-5535	Nozzle, Back	1
11	3-3536	Ring, Snap, Head	1
12	363-3210	O-Ring, .139" x 4.359" x 4.637"	1
13	9-1849	Drive Assy., Quarter Circle, 691 (Includes Item 14)	1
13	9-1850	Drive Assy., Half Circle, 692 (Includes Item 14)	1
13	3-3585	Drive Assy., Full Circle, 694 (Includes Item 14)	1
13	35-5123	Drive Assy., Full Circle, 696, 2-Speed, 60°-120° (Includes Item 14)	1
13	89-8145	Drive Assy., 150° (Includes Item 14)	1
13	89-8146	Drive Assy., 165° (Includes Item 14)	1
13	89-8147	Drive Assy., 195° (Includes Item 14)	1
13	89-8148	Drive Assy., 210° (Includes Item 14)	1
14	9-2736	Collar, Spring	1
15	3-3586	Stator, 3/8", #90	1
15	3-3568	Stator, 7/16", #91	1
15	3-3555	Stator, 1/2", #92	1
16	3-3304	Ring, Snap, Valve	1
17	9-1479	Cylinder Assy., Hyd., NO, COM & Drain Valve	1
17	9-1486	Cylinder Assy., EI & Hyd., NC	1
18	3-3311	Spring, Valve, COM	1
18	3-3323	Spring, Valve, EL, Hyd., NO, Hyd., NC & Drain Valve	1
19	89-1201	Piston Assy., Valve, Hyd., NO & COM	1
19	3-3355	Piston Assy., Valve, Drain	1
19	89-0937	Piston Assy., Valve, EI, Hyd., NC	1
20	- - - - -	Body, 690 (See Service Items)	1
21	9-6002	Adapter, Tubing, Threaded, 1/4"	1
22	* 89-8157	Cap, Poly, 1/4"	1
23	* 900-40	Retainer, Tube	2
24	9-2624	Tubing, Poly 16.5"	1
25	See page 9	Pilot Valve Assy.	1
26	3-2696	Screw, Tap, #8	2
27	3-3581	Cover, Body, Rubber	1
		SERVICE PARTS AND ASSEMBLIES	
	2-9647	Screw, Machine, 10-24 x 1-1/2"	1
	3-2606	Adapter, Poly, 1/4", COM	1
	3-3579	Body, Electric w/VIH (Includes Items 20-23)	1
	89-4861	Body, Electric w/VIH (Includes Items 16-23)	1
	89-4873	Body, Electric w/VIH, 80 lb. PV (Includes Items 16-21 and 23-26)	1
	89-1019	Body, Electric w/VIH, 100 lb. PV (Includes Items 16-21 and 23-26)	1
	3-3558	Body, Hydraulic NO w/VIH (Includes Items 20-23)	1
	89-1038	Body, Hydraulic NO w/VIH (Includes Items 16-23)	1
	9-1497	Body, COM w/VIH (Includes Items 20, 21, 23 and 24)	1
	89-4879	Body, COM w/VIH (Includes Items 16-21, 23 and 24)	1
	89-0088	Pilot Valve Assy, 100 Lbs. w/Tubing	1
	9-4079	Nozzle Assy., 690-90 (Includes Items 7-10)	1
	9-4080	Nozzle Assy., 690-91 (Includes Items 7-10)	1
	9-4081	Nozzle Assy., 690-92 (Includes Items 7-10)	1
	9-4083	Nozzle Assy., 694-90 (Includes Items 7-10)	1
	9-4084	Nozzle Assy., 694-91 (Includes Items 7-10)	1
	9-4085	Nozzle Assy., 694-92 (Includes Items 7-10)	1
	9-5747	Nozzle Base Assy., 690	1
	9-2669	Retraction Assy., Spring (Includes Items 5, 6,11 & 14)	1
	690-01	Kit, Cover, Rubber (Includes Items 1, 3 & 27)	1
	9-7271	Adapter, Tubing, Oversized	1
		* Order through Finished Goods Distribution System – Minneapolis	

